

User Manual / Installation Guide

Model No. 1500TS

Warning! It will cause malfunction if the monitor is operating with unspecified power supply adaptor or incorrect power voltage. Do not expose this unit in the rain or moisture environment to reduce the risk of fire or electric shock.

PRECAUTIONS

- Do not use the monitor near water.
- Do not place the monitor on an unstable cart, stand, or table. If the monitor falls, it can injure a person and cause serious damage to the appliance. Use only a cart or stand recommended by the manufacturer or sold with the monitor. If you mount the monitor on a wall or shelf, use a mounting kit approved by the manufacturer and follows the kit instructions.
- The monitor should be operated with type of power adaptor indicated on the label. Normally it is packed with monitor, or using an adaptor approved by the manufacturer.
- Unplug the unit during a lightning storm or when it will not be used for long periods of time. This will protect the monitor from being damaged due to power surges.
- Never spill liquids on the monitor.
- Do not attempt to service the monitor yourself; opening or removing covers can damage to the monitor or panel. Please refer all servicing to qualified service personnel.
- For Wall mount adaptor, wall socket shall be installed near the equipment and shall be easily accessible.

?



Index:

I.	Introduction -----	3
	Features-----	3
	Unpack the monitor-----	3
	Check Accessories-----	3
II.	Installation -----	4-6
	Power Supply & Signal connection -----	4
	Capacitive Touch Key Control-----	4
	Structure of OSD settings-----	5
III.	For your safety -----	6
IV.	Support timing -----	6
V.	Resistive Touch Panel -----	6~10
	Touch Driver installation -----	6~10
VI.	Mechanical dimension -----	11
VII.	EMC Warning Statement -----	12
	FCC Class A Warning -----	12
	CISPR 22 class A Warning -----	12
VIII.	Product General Specification -----	13

I. **Introduction**

- This monitor produces clear images with the vivid color at resolutions from VGA up to XGA and used with graphics adapter of scanning frequency from 30KHz to 82KHz in horizontal sweep while vertical refresh rate is 56Hz to 76 Hz continuously.
- On Screen Display provide flexibility with simple & user-friendly controls.
- Integrated D-sub and HDMI inputs provide flexible connectivity for high-definition multimedia devices and gaming consoles
- Optional built-in 2W x2 Speakers
- USB interface 5-Wire Resistive Touch Panel

➤ **Features**

- 15 inch diagonal screen with native display resolution 1024 * 768
- Dual Video input: VGA, HDMI
- Full flat front panel with high quality resistive touch panel
- Fully Glossy surface throughout monitor's appearance.
- Rimless front bezel design, spill & dust proof
- Cable management down routing through the mounting stand
- Light weight, only 3290g physically.
- 5 Wires Resistive Touch Panel Control Function

➤ **Unpack the monitor**

- Put the monitor on a clean surface; make sure the box in upright position.
- Remove packing materials from inside of box.

➤ **Check accessory**

Please make sure the entire accessory is included:



1.8 meter VGA 15 pin
D-sub Video cable



Power Adaptor



USB cable

II. Installation:

➤ **Power Supply & Signal connection:**

Power supply: Use DC 12Vdc power.

HDMI signal: Apply HDMI signal

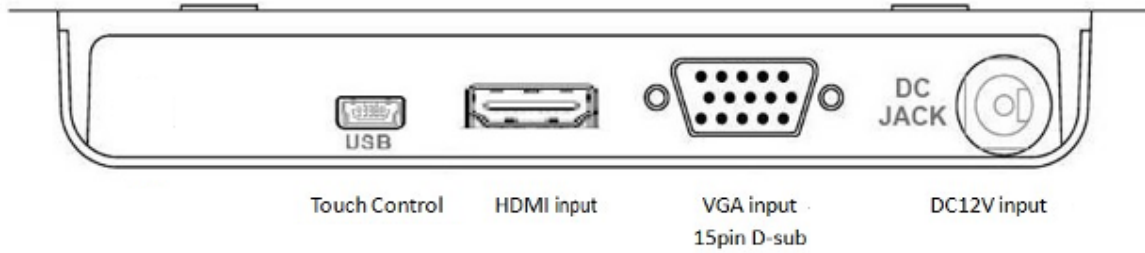

➤ **Capacitive Touch Key Control /Connectors**



<p>Power ()</p>	<p>U Use the power switch to turn the power ON or OFF. We recommend turning your system power on first, then the LCD monitor. Press Power key to turn on and Press again for 2~3sec. to power off monitor</p>
<p>Auto Adjust (AUTO)</p>	<p>a. Pressing to execute AUTO-Adjusting function. This function will optimize the display image b. Sometimes this function can't achieve the optimal effects. Please follow the manual adjusting procedure. c. After OSD menu is activated, press this key can turn off the OSD menu.</p>
<p>Menu (MENU)</p>	<p>a. Press Menu key to activate OSD Menu b. This key also means "OK"; Press "Up, Down" key to move the indicator to the desired item, then press Menu key to select and read to adjust.</p>

	After adjustment, press this key to return to previous Menu.
Up (▲)	a. When OSD mode is activated (When “MENU” key is pressed). These two keys are used to select the adjustment items.
Down (▼)	b. When adjustment item is selected, these two keys are defined to decrease or increase the value of each selected item. c. Direct access “Up” Key will reveal Brightness OSD for adjustment. Direct access “Down” key will reveal Volume OSD for adjustment.

➤ **OSD Lock / Unlock :**

Press “Menu” Key for more than 7 seconds shall lock all control keys function.
After keys locked, press “Menu” key again for more than 7 second shall unlock the key function.

➤ **Structure of OSD settings**

Man Menu:

	Level 1	Level 2	Level 3	Operating Procedure
Main Menu	Auto Adjust			Press “UP” or “DOWN” to adjust H-phase & H-position & V-position clock automatically.
	Luminance	Brightness		Press “UP” key to increase brightness, “DOWN” key to decrease brightness.
		Contrast		Press “UP” key to increase contrast, “DOWN” key to decrease contrast.
		Sharpness		Press “UP” key to increase image sharpness, “DOWN” key to decrease image sharpness.
		Exit		Exit to previous Menu
	Management	H. Position		Press “UP” key to shift screen left, “DOWN” key to shift screen right.
		V. Position		Press “UP” key to shift picture upward, “DOWN” key to shift picture downward.
		Pixel Clock		To reduce any vertical bars or strips visible on the screen background. Adjusting the Clock will also change the horizontal screen image width
		Phase		To remove any horizontal noise and clear or sharpen the image of characters.
		Exit		Exit to previous Menu
Color	9300K 6500K 5400K			Press “UP” or “DOWN” to choose three types of color temperature 9300°k, 6500°k, sRGB and user define.
	User Preset	Red Green Blue Exit		Select User Preset to enter Color Adjust Menu, Select desired color to adjust
	Exit	-		Exit to Main Menu
OSD	H. Position			Adjust OSD Menu horizontal position, press “UP” key to shift Menu right, “DOWN” key to shift Menu left
	V. Position			Adjust OSD Menu vertical position, press “UP” key to shift Menu upward, “DOWN” key to shift Menu downward
	OSD Time		-	Sets the time duration in seconds that the OSD is visible after the last button is pressed.
	Exit			Exit to previous Menu
Language	English Francais Deutsch Italino Espanol		-	Press Up/Down key to move OSD bar to desired language, Then press to confirm, the OSD Menu will change to desired language and return to Main Menu.

		日本語 繁體中文 简体中文 Portuguese 한국어 русский		
Main Menu	Recall	Recall color	Yes No	Press "Yes" to reset Color to factory setting
		Recall All	Yes No	Press "Yes" to rest all settings back to factory setting, except language
		Exit		Press "Ext" to return to Main Menu
Information	Display information		-	Press Display information to display resolution and refresh rate Press "Exit" to return to Main Menu
	Exit			
Ext		-	-	Press "Exit" key will close OSD Menu and save the settings

Source Select Menu: Direct press "Down" key can select video source

VGA HDMI

III. **For your safety**

1. When move the monitor, always switch off power and disconnect all cables to avoid any danger.
2. Please use the power and signal cables correctly when install it.
3. In case of notice any abnormal smell or noise, please stop operation and call the nearest dealer or service center.

IV. **Support timing chart:**

Timing Mode	Reference Standard	Resolution	Pixel MHz	FH KHz	FV Hz	Interlace	H Polarity	V Polarity
Mode 1	VESA	1024 x 768	65.00	48.363	60.004	NO	-	-
Mode 2	VESA	1024 x 768	75.00	56.476	70.069	NO	-	-
Mode 3	VESA	1024 x 768	78.75	60.023	75.029	NO	+	+
Mode 4	VESA	800 × 600	36.00	35.156	56.250	NO	+	+
Mode 5	VESA	800 × 600	40.00	37.879	60.317	NO	+	+
Mode 6	VESA	800 × 600	50.00	48.077	72.188	NO	+	+
Mode 7	VESA	800 × 600	49.50	46.880	75.000	NO		
Mode 8	VGA	640 x 480	25.17	31.47	59.94	NO	-	-
Mode 9	MAC	640 x 480	30.24	35.00	66.67	NO	-	-
Mode 10	VGA	720 x 400	28.32	31.47	70.08	NO	-	+

V. **Resistive Touch Panel:**

Panel:

Type : Five-Wires Analog Resistive

Input Mode : Five-Wires Analog Resistive

Transparency : 80% +/- 5%

Build-in Touch Control Module

(Note: For Panel Touch Control, user need to connect upstream cable to System PC)

Control type : USB

Touch Control Driver : eGalax Touch Drivers



Touch Driver installation:

1.0 Screen display as below, please click Next>.

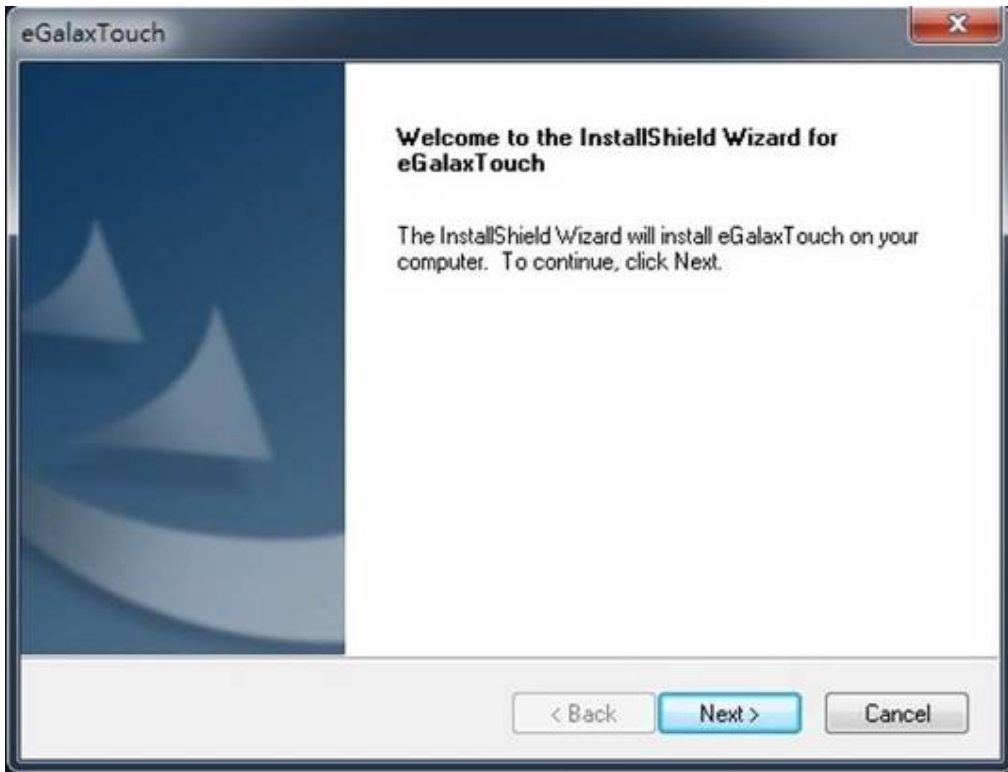

2.0 Select the set up type, don't tick the box if PS2 interface is not required, Click "Next>"

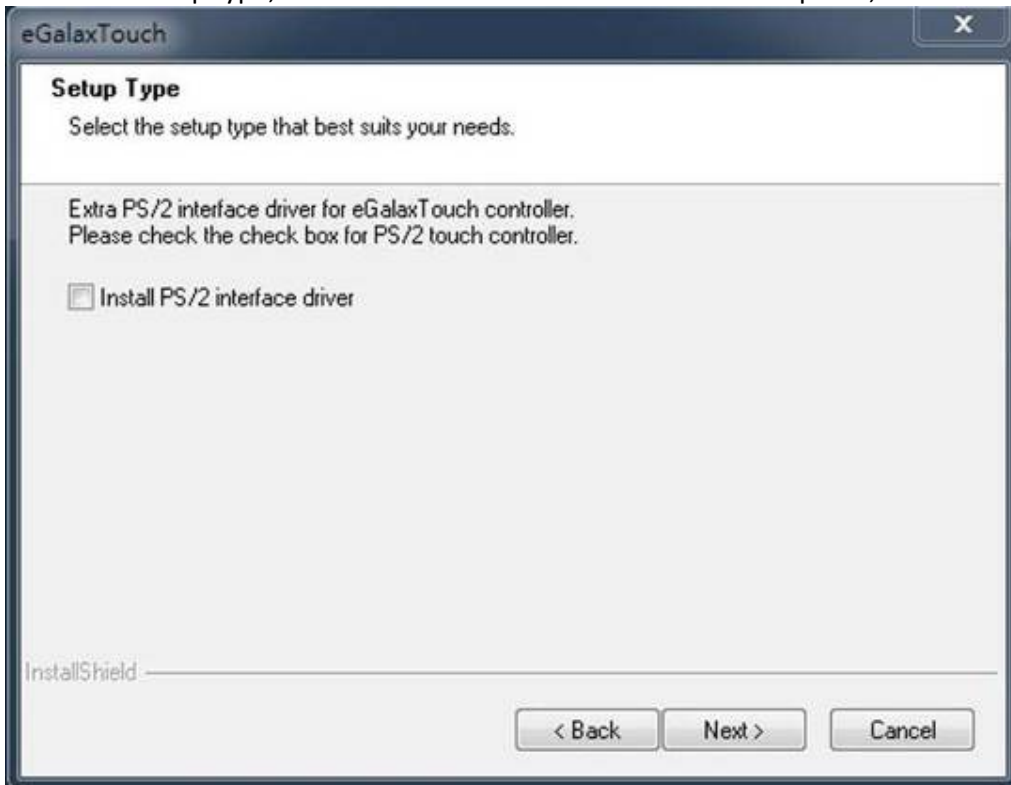

3.0 RS232 interface driver installed is default, please click Next>

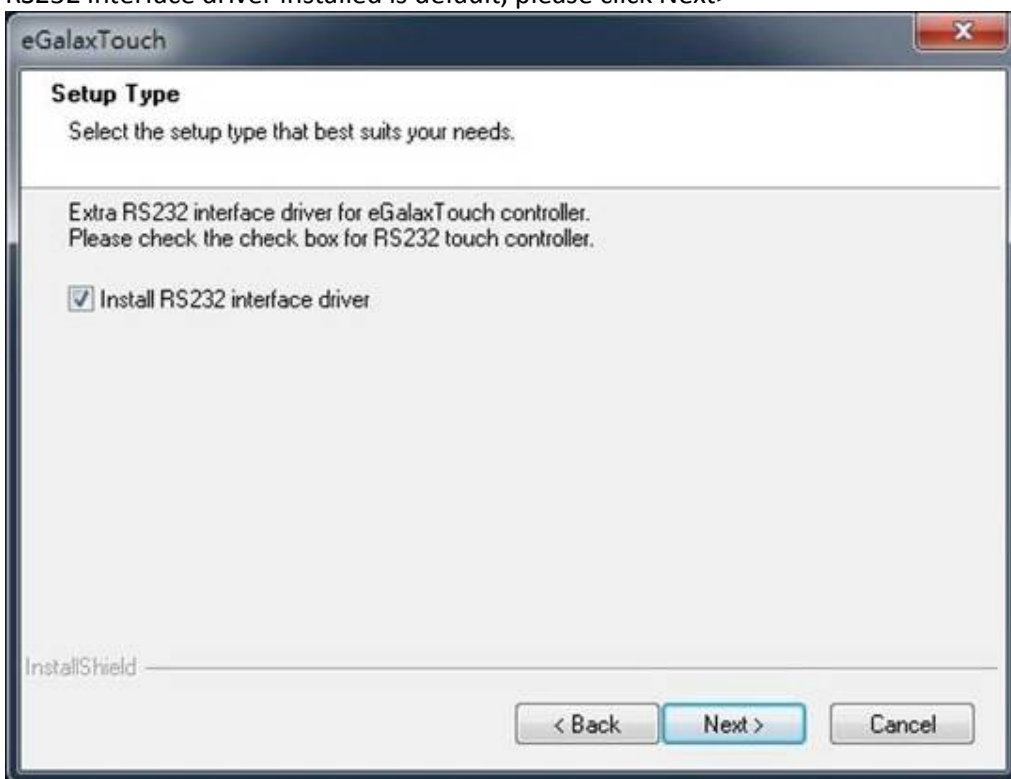

4.0 You can select to do Touch screen calibration after system boot up or not Default setting is" None"

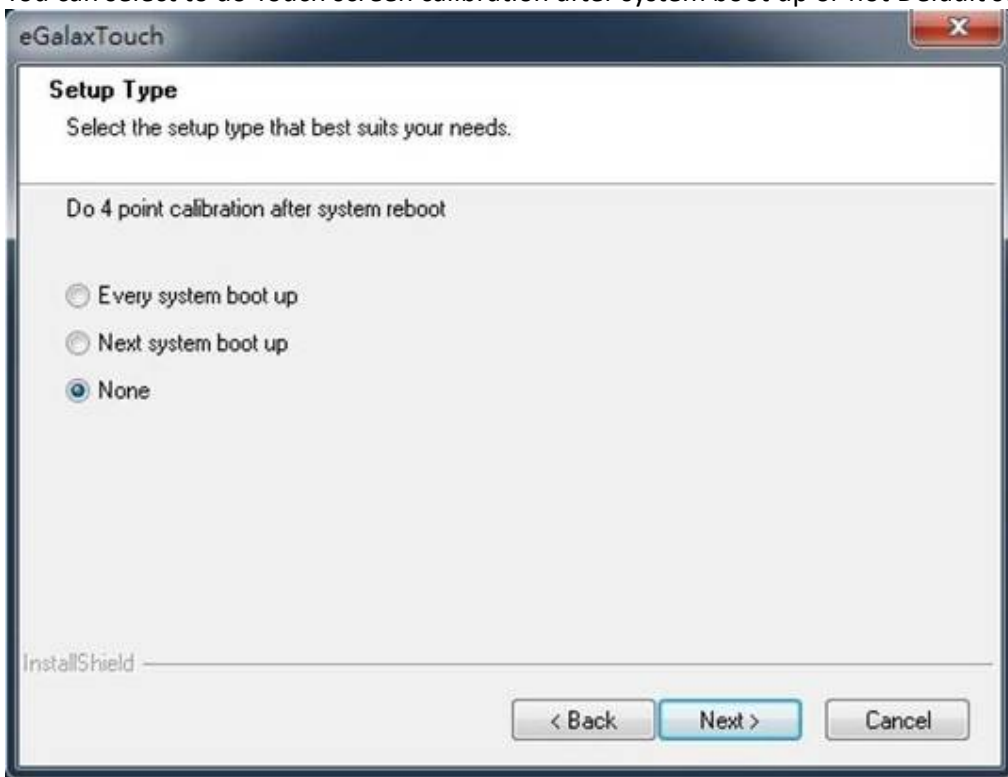

5.0 Select to use Multi-Monitor system, then press Next>

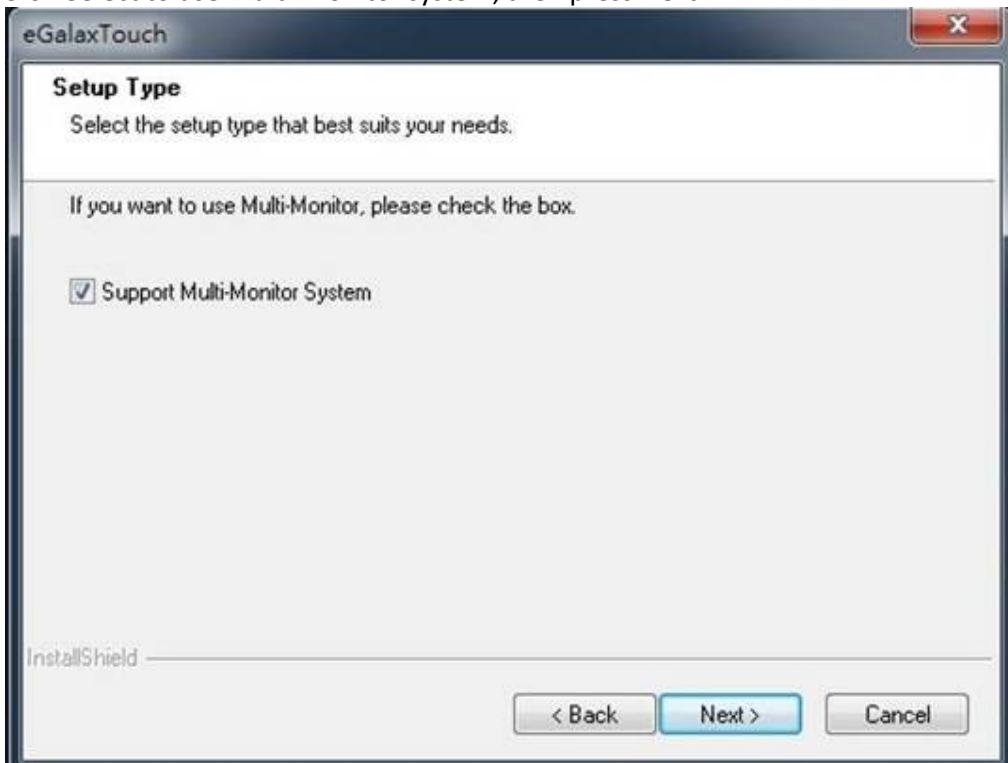

6.0 Choose destination location, default folder location shown as below.

Press Next>

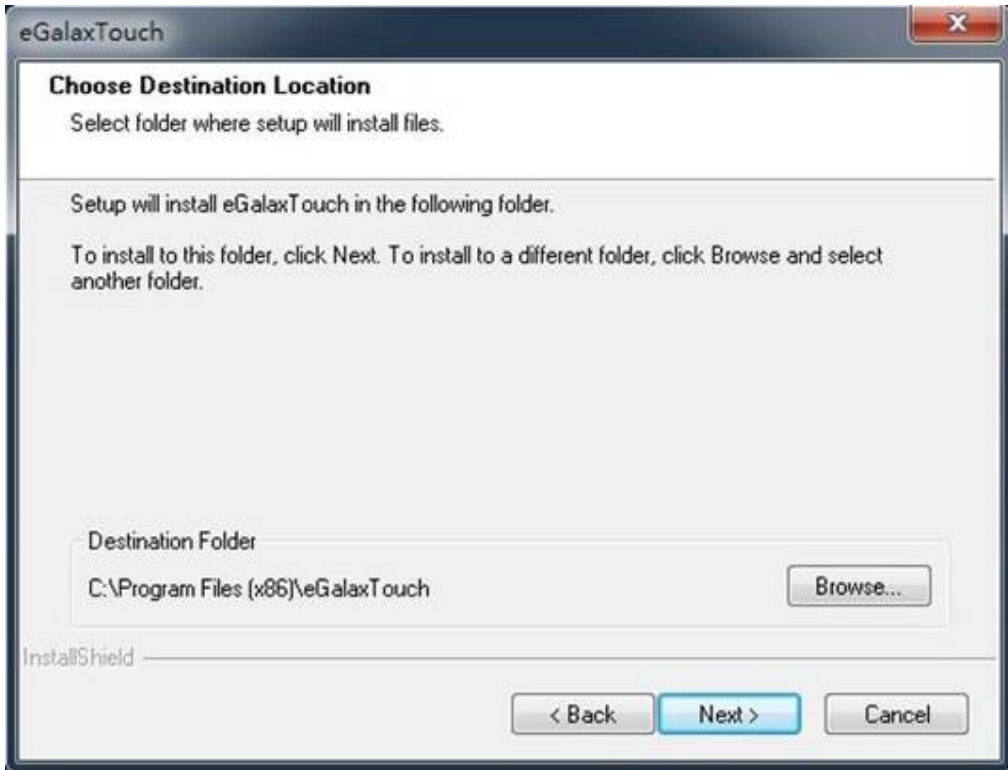

7.0 Figure shown below, please press Next> to complete installation



VI. Mechanical dimension

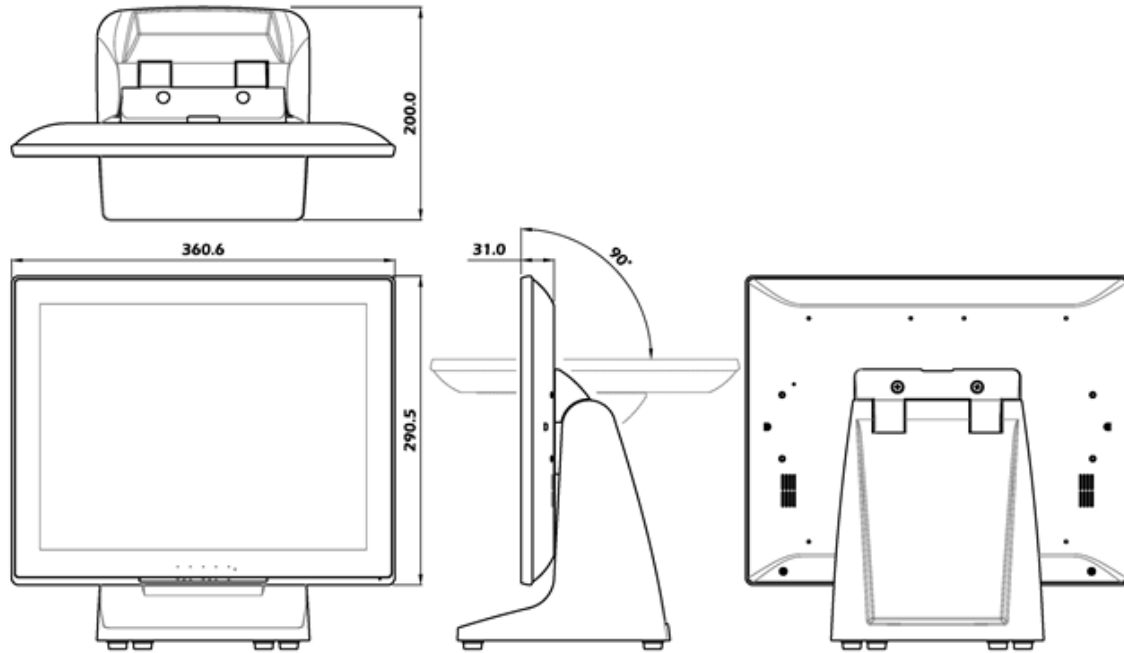

VII. EMC Warning:

FCC Class A Warning



Warning

This equipment has been tested and found to comply with the limits for a Class A digital device, pursuant to Part 15 of the FCC Rules. These limits are designed to provide reasonable protection against harmful interference when the equipment is operated in a commercial environment. This equipment generates, uses, and can radiate radio frequency energy and, if not installed and used in accordance with the instruction manual, may cause harmful interference to radio communications. Operation of this equipment in a residential area is likely to cause harmful interference in which case the user will be required to correct the interference at his own expense.

CISPR 22 Class A Warning



Warning

This is a class A product. In a domestic environment this product may cause radio interference in which case the user may be required to take adequate measures.

VIII. Product General Specification:

Model	1500TS
Cabinet color	Black
LCD Panel	
Display size	15"
Active Area	304.1mm x 228.1mm
Optimal Resolution	1024 x 768
Color Arrangement	RGB-stripe
Brightness	300 cd/m ² (typ)
Contrast Ratio	800:1
Response Time	8 ms (typ.)
Viewing Angle	V: 80 /80 , H: 80 /80
Input Video Format	VGA
Input Video signal connector	VGA D-sub 15pin 19 pin HDMI
Input Frequency	H: 30 - 60 kHz ; V: 55-76Hz
DC Power input	12Vdc 1.5A
DC Jack	Center pin diameter = 2.0mm
Temperature	Operating : 0°C~40°C Storage : -10°C ~50°C
Humidity	Operating : 20%~80% Storage : 10%~90%
Weight	3290g (net)
Approvals	CE, FCC
Wall Mount	VESA 75 * 75 mm
Resistive Touch Panel Type	Five-Wire Analog Resistive
Input Mode	Stylus or Finger
Touch Control type	USB
Touch Control Driver	eGalax Touch

*Product specification to be changed without prior notice

*Made In Taiwan