

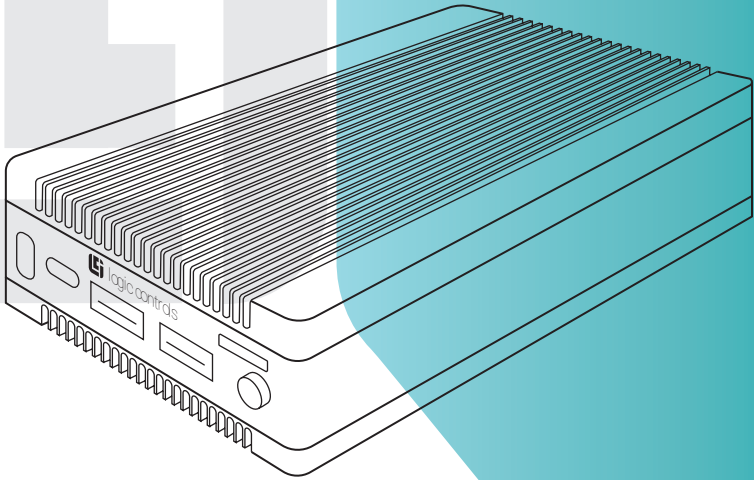

 logic controls

LS-8900

Kitchen Display Station Controller
with Ethernet Interface



User Manual And
Installation Guide

Notice

The manufacturer of the kitchen video controller makes no representations or warranties, either expressed or implied, by or with respect to anything in this manual, and shall not be liable for any implied warranties of fitness for a particular purpose or for any indirect, special or consequential damages. Information in this document is subject to change without notice and does not represent a commitment on the part of the manufacturer.

FCC Notice

This device complies with Part 15 of FCC Rules. Operations are subject to the following two conditions: (1) this device may not cause harmful interference, and (2) this device must accept any interference received, including interference that may cause undesired operation.

European Community Mark Of Conformity (CE)

This product is in conformity with the protection requirements of EU Council Directive 89/336/EEC on the approximation of the laws of the Member States relating to electromagnetic compatibility. Logic Controls cannot accept responsibility for any failure to satisfy the protection requirements resulting from a non-recommended modification of the product. This product has been tested and found to comply with the limits for Class A Information Technology Equipment according to CISPR 22 / European Standard EN 55022.

The limits for Class A equipment were derived for commercial and industrial environments to provide reasonable protection against interference with licensed communication equipment.

Warning:

This is a Class A product. In a domestic environment this product may cause radio interference in which case the user may be required to take adequate measures.



Logic Controls, Inc.

404 Sunport Ln.

Suite 550

Orlando, FL 32809

Tel: +1 516 248 0400

www.logiccontrols.com

Important Safety Instructions

Please read the following instructions carefully and save these instructions for future reference.

- 1.** Follow all warnings and instructions for installation and operation of the product.
- 2.** Unplug this product from the wall outlet before cleaning. Use only mild cleaning agents and do not immerse in water.
- 3.** Do not use this product near water.
- 4.** This product should be operated from the type of power indicated on the power adaptor. If you are not sure of the type of power available, consult your dealer or local power company.
- 5.** Do not allow anything to rest on the power cord. Do not locate this product where persons will walk on the cord.
- 6.** If an extension cord is used with this product, make sure that the total ampere rating of the equipment plugged into the extension cord does not exceed the extension cord ampere rating. Also, make sure that the total rating of all products plugged into the wall outlet does not exceed the fuse rating.
- 7.** We recommend all servicing done on this product be done by qualified service personnel. Aside from upgrades or swapping out the compact flash please refer all other servicing to the Logic Controls RMA Dept or a repair provider that has been certified by Logic Controls.
- 8.** Unplug this product from the wall outlet and refer servicing to qualified service personnel under the following conditions:
 - a.** When the power cord or plug is damaged or frayed
 - b.** If liquid has been spilled into the product
 - c.** If the product has been exposed to rain or water
 - d.** If the product does not operate normally when the operating instructions are followed. Adjust only those controls that are covered by the operating instructions since improper adjustment of other controls may result in damage and will often require extensive work by a qualified technician to restore the product to normal condition.
 - e.** If the product has been dropped or the cabinet has been damaged
 - f.** If the product exhibits a distinct change in performance, indicating a need for service.

Table of Contents

5	Features
6	Product Description
7	Installation
9	Specifications
10	Troubleshooting
11	Warranty

The LS-8900 combines all the qualities you need to operate as a POS system or Kitchen Display System, with a compact and solid design that is capable of fitting in difficult spaces providing the device with functional and impeccable appearance.

Highly Reliable

- Low power operation, low internal temperature rise
- Simple hardware and no disk drive (no moving parts)
- Rugged die-cast housing
- Standard Ethernet network connection
- Tamper proof, no on/off and option switches, no adjustable devices
- Touch-screen support (USB interface)

Low Cost

- PC workstations NOT required
- Network software NOT required
- Network cards NOT required
- I/O expansion hardware NOT required
- Simplified installation and setup

Compact Size

- Module size: 4.9"W x 3.1"L x 1.2"H (12.4cm x 7.9cm x 3.15cm)
- Flexible Installation: Table Mount, Wall Mount, Display Bracket Mount, and Under-the-Counter Mount

Compatible OS

- Android (Ver 7.1 standard included)
- Ubuntu
- Phoenix OS
- Debian 9

Product Description

The LS8-900 comes packed with everything required to succeed in the harshest of kitchen environments, with the most up-to-date connectivity to satisfy a wide array of varying needs. From allowing connectivity to an amplitude of different devices, to supporting high-speed internet connections, there are multiple ways to get the most out of this multi-faceted device.



Power/Status LED

The power/status LED is located on the front of the LS-8900. A light indicates that power is ON.



Displays

LS-8900 supports standard color HDMI displays with a HDMI 2.0 port connector.



Connectivity

The LS-8900 allows simultaneous connections with 1 USB 3.0 port, 1 USB 2.0 port, 1 USB type C port, 1 ethernet 10/100/1000Mbps port, and 1 TF card port

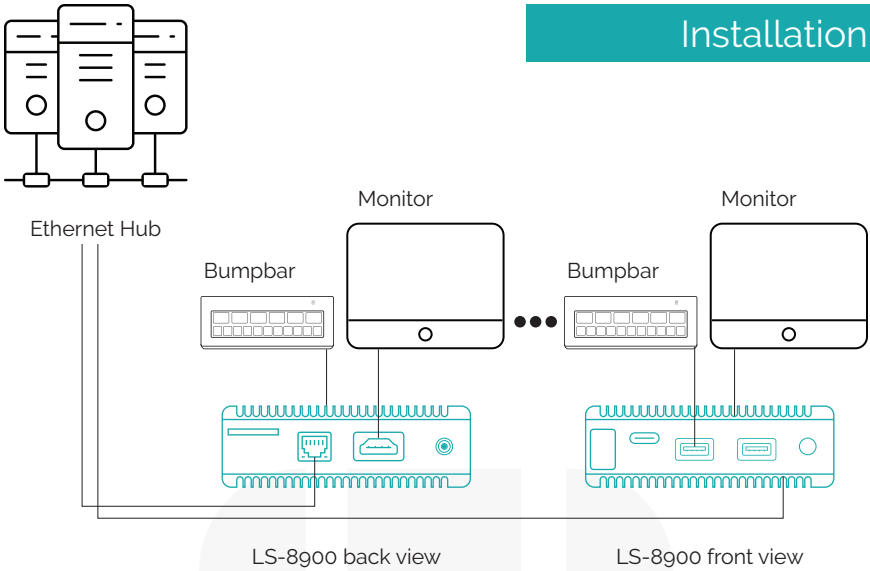

Make sure that all systems are powered off before making or removing any connections to the LS-8900 unit. Follow the steps below in connecting the devices:

- 1 Connect the cable of the display monitor to the LS-8900.
- 2 Connect the bumpbar or keyboard device to the LS-8900
- 3 Connect the Ethernet cable from Ethernet hub or switch to the LS-8900.
- 4 Connect power to all peripheral devices and turn on power.
- 5 Connect power adapter to the LS-8900.
- 6 Plug the power adapter into AC power outlet.
- 7 Press the ON/OFF button to turn the LS-8900.

Installation

Setup

The LS-8900 KDS station communicates with POS stations or KDS router through Ethernet connection. To do the initial setup of the LS-8900, follow steps below.

- 1 Connect LS-8900 to POS station or KDS router.
- 2 Connect the LS-8900 power cable to the outlet.
- 3 As soon as the LS-8900 has been connected to the outlet, it should automatically turn on.
- 4 To set up the network, connect the Ethernet port to the LS-8900.
- 5 If any adjustments are necessary, click the "Settings" app, and adjust accordingly.

App Installation

To install any extra applications, follow steps below:

- 1 Copy APK file of the app into a flash drive.
- 2 Plug the flash drive into one of the USB ports of LS-8900.
- 3 Click on Apps icon.
- 4 Click on "Explorer" app.
- 5 Click "USB Storage", and browse and click the application APK file to start the installation.

Mechanical

Weight	2.25 lbs (1.02Kg)
Dimension (WxHxD)	4.9in x 3.1in x 1.2in (12.4cm x 7.9cm x 3.15cm)

System

CPU:	6-core ARM® 64-bit processor, frequency up to 1.8 GHz Based on big.Little architecture, Dual-core Cortex-A72 (big core) + Quad-core Cortex-A53(little core)
Chipset:	Rockship RK3399
RAM:	4GB LPDDR4 dual-channel 64-bit RAM
Storage:	Onboard SPI flash (16MB), Optional high-speed eMMC(16GB/32GB/128GB), Support MicroSD(TF card), USB flash disk expansion, Support expansion board M.2 M-Key to expand SSD

Video

GPU:	Mali-T860 MP4 quad-core GPU, support Open GL ES1.1/2.0/3.0/3.1, OpenVG1.1, OpenCL, DX11
------	---

Electrical

Voltage	DC12V-2A (5.5"2.1mm) Support POE+ (802.3 AT, output power 30w)
User Key	Power Key, Reset Key MASKROM (BOOT) key Recovery
LED	Power LED (Red) STAT LED (Green)

I/O Ports

USB	1 x USB 2.0 1 x USB 3.0 1 x Type-C (USB3.0 / DP1.2/ OTG)
Ethernet:	10/100/1000Mbps Gigabit Ethernet (RJ45 interface)
Display:	HDMI2.0 support 4K 60Hz display, support HDCP 1.4/2.2 DP1.2 (DisplayPort 1.2 support up to 4K 60Hz)/p> Support eDP 1.3, support MIPI-DSI(dual channel) Support Type-C + HDMI dual display, support 4k + 2k output
Audio:	1 x Phone (3.5 mm), 1 x HDMI, 1 x DP support LINE_IN and LINE_OUT
IR:	Support infrared remote control

LS-8900 does not turn on.



- 1 Check the power cable port. Make sure the cable is plugged in the "DCIN/OTG" port, and not the "USBC/DP" port.
- 2 Make sure the electrical outlet works.
- 3 Reset the LS-8900.

The LS-8900 turns on, but nothing shows up on the display



- 1 Make sure the cable is plugged in correctly into the HDMI port.
- 2 When using a DVI or VGA adapter, make sure the adapter works.
- 3 Reset the LS-8900.

Ethernet connection is not working



- 1 Make sure the ethernet cable is plugged properly and is not faulty
- 2 Check to see if the lights on the ethernet port are on.
- 3 Reset the LS-8900

NOTE:

For Warranty information on your product, please visit:

<https://logiccontrols.com/warranties-policies/>

Return and Repair Process

To return Logic Controls products for repair during the warranty period or after expiration of the warranty period, a valid Return Merchandise Authorization (RMA) number from Logic Controls Customer Service Department is required. To obtain an RMA please go to the [support page on our website](#). The RMA number, customer name and location must be clearly indicated on the outside of the returned package and on the enclosed packing list. Logic Controls cannot be held responsible for any products with packaging returned without an authorized RMA number. The Customer is responsible for packing the returned unit properly and for the cost of shipping the unit to Logic Controls. Additional damage caused in shipping due to poor packaging becomes the responsibility of the customer. Return shipping charges will be paid by Logic Controls on products under warranty via normal ground service for customers in the continental United States. Customers in all other geographies are responsible for return shipping charges from Logic Controls, FL. The customer is responsible for shipping charges to and from Logic Controls for products out of warranty or deemed not eligible for warranty coverage.

RMA Procedure

- 1 Download an RMA shipping label form (**Please note that this is not a pre-paid shipping label. ***)
- 2 Please mail RMA label to:
Logic Controls
404 Sunport Ln.
Suite 550
Orlando, FL 32809
- 3 For further assistance:
Phone: 516-248-0400 Option 2 for Support
Website: www.logiccontrols.com
Email: support@logiccontrols.com
Hours of Operation: 9:00 a.m. to 5:30 p.m. ET, Monday – Friday

RMA Process outside USA

If you are located outside the United States, please contact your local dealer, or check our website for more information.



LS8900UMIE20200904

logiccontrols.com | sales@logiccontrols.com | 516.248.0400