

TM-L90

Liner-Free Label Paper Model

Technical Reference Guide

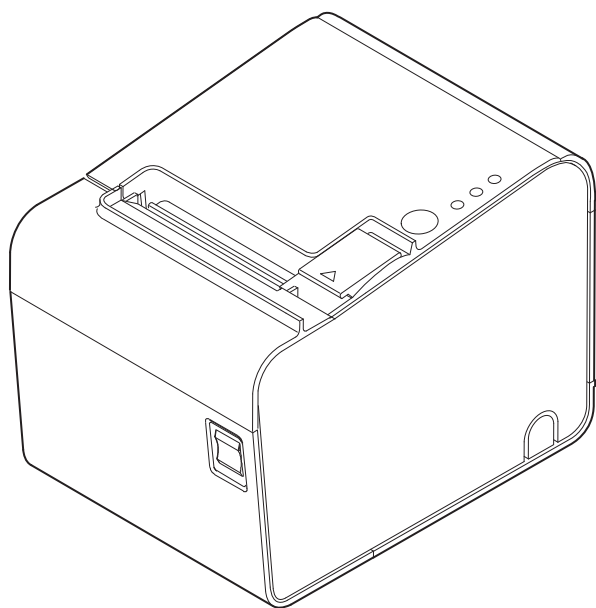

Product Overview

Describes the features of the product.

Setup

Describes the setup and installation of the product and peripherals.

Advanced Usage

Describes the advanced usage of the product.

Application Development Information

Describes how to control the printer and gives information useful for printer application development.

Handling

Describes the basic handling of the printer.

Appendix

Describes the product specifications, interface specifications, and character code.

CAUTION

- No part of this document may be reproduced, stored in a retrieval system, or transmitted in any form or by any means, electronic, mechanical, photocopying, recording, or otherwise, without the prior written permission of Seiko Epson Corporation.
- The contents of this document are subject to change without notice. Please contact us for the latest information.
- While every precaution has been taken in the preparation of this document, Seiko Epson Corporation assumes no responsibility for errors or omissions.
- Neither is any liability assumed for damages resulting from the use of the information contained herein.
- Neither Seiko Epson Corporation nor its affiliates shall be liable to the purchaser of this product or third parties for damages, losses, costs, or expenses incurred by the purchaser or third parties as a result of: accident, misuse, or abuse of this product or unauthorized modifications, repairs, or alterations to this product, or (excluding the U.S.) failure to strictly comply with Seiko Epson Corporation's operating and maintenance instructions.
- Seiko Epson Corporation shall not be liable against any damages or problems arising from the use of any options or any consumable products other than those designated as Original Epson Products or Epson Approved Products by Seiko Epson Corporation.

Trademarks

EPSON is a registered trademark of Seiko Epson Corporation.

Exceed Your Vision and ESC/POS are registered trademarks or trademarks of Seiko Epson Corporation.

Microsoft and Windows are registered trademarks of Microsoft Corporation in the United States and/or other countries.

All other trademarks are the property of their respective owners and used for identification purpose only.

ESC/POS® Command System

EPSON ESC/POS is a proprietary POS printer command system that includes patented or patent-pending commands. ESC/POS is compatible with most EPSON POS printers and displays.





ESC/POS is designed to reduce the processing load on the host computer in POS environments. It comprises a set of highly functional and efficient commands and also offers the flexibility to easily make future upgrades.

©Seiko Epson Corporation 2019. All rights reserved.

For Safety

Key to Symbols

The symbols in this manual are identified by their level of importance, as defined below. Read the following carefully before handling the product.

 WARNING	You must follow warnings carefully to avoid serious bodily injury.
 CAUTION	Provides information that must be observed to prevent damage to the equipment or loss of data. <ul style="list-style-type: none">• Possibility of sustaining physical injuries.• Possibility of causing physical damage.• Possibility of causing information loss.
 CAUTION	Provides information that must be observed to avoid damage to your equipment or a malfunction.
 NOTE	Provides important information and useful tips.

Warnings

 WARNING	<ul style="list-style-type: none">• Do not cover the printer with cloth or place it in a poorly ventilated location.• The internal temperature may increase, leading to fire.• Keep the printer away from volatile substances, such as alcohol and thinner, and fire. Failure to do so may result in electrical shock or fire.• Shut down your equipment immediately if it produces smoke, a strange odor, or unusual noise. Failure to do so may result in electrical shock or fire.• If an accident occurs, turn off the power immediately and unplug the AC cable. Then contact qualified service personnel.• If foreign matter or liquid such as water spills into this equipment, do not continue to use it. Continued use may result in electrical shock or fire.• Immediately unplug the equipment and contact qualified service personnel.• Do not disassemble the printer except for the locations indicated in the manual.• Never attempt to repair this product yourself. Improper repair work can be dangerous.• Do not use the printer in a location where flammable gas, explosive gas, or similar gas might exist in the air. Do not use aerosol sprayers containing flammable gas inside or around this product. Doing so may cause fire.• Do not connect cables in ways other than those indicated in this manual.• Doing so may lead to fire. Doing so may also damage the connected equipment.• Do not insert or drop metal or flammable objects into the printer from the openings. Doing so may result in electrical shock or fire.• Make sure to use this product at the specified voltage. Failure to do so may result in fire or electrical shock.
--	---



WARNING

- Check that the plug is clean before plugging it in. Failure to do so may result in electrical shock or fire.
- Be sure to push the plug all the way in. Failure to do so may result in electrical shock or fire.
- Do not use a damaged power cable. Doing so may result in electrical shock or fire.
- If the power cable is damaged, contact qualified service personnel.
- Do not place multiple loads on the power outlet. Overloading the outlet may lead to fire.
- Be sure to disconnect the plug from the power outlet and clean the base of the blades and the area between the blades. Leaving the plug inserted in the power outlet for a long time may cause dust to stick to the base of blades, leading to fire.
- When you disconnect the plug from the power outlet, hold the plug and do not pull the cable. Failure to do so may damage the cable or deform the plug, resulting in electrical shock or fire.
- When handling the AC adapter, observe the instructions described below. Failure to do so may result in electrical shock or fire.
 - * Avoid exposure to rain or water.
 - * Do not hang the adapter on the power cable.
 - * Avoid contact between a metal object such as a paper clip and the connector.
 - * Do not cover the adapter with a blanket or similar item.
- Do not insert a telephone line into the drawer kick connector. Doing so may damage the telephone line or printer.
- Do not place the printer in a dusty or humid location. Doing so may result in electrical shock or fire.
- Before relocating this product, turn off the power, disconnect the plug from the power outlet, and make sure that all the cables are disconnected. Failure to do so may result in electrical shock or fire.

Cautions



CAUTION

- Do not place/store the printer on an unsteady location or a location subject to the vibration of other equipment. Otherwise, the product may break or cause injury if it falls.
- Do not place heavy objects on top of this product. Never stand or lean on this product. Otherwise, the product may fall or break and cause injury.
- When connecting cables or installing optional products, follow the procedures and make sure that the cables and products are installed in the proper direction. Failure to do so may cause injury.
- Follow the instructions in the manual for proper installation.
- While opening/closing the printer cover, keep your hands away from the joint between the cover and the main body. Otherwise, your hand or finger may be pinched and get injured.
- To ensure safety, unplug this product when leaving it unused for an extended period.
- Do not touch the inside of the printer except for the locations indicated in the manual. Doing so may result in electrical shock or burns.
- Observe the instructions below to prevent the power cable from being damaged.
- Do not modify or attempt to repair the cable
- Do not place any heavy object on top of the cable
- Avoid excessive bending, twisting, and pulling
- Do not place the cable near heating equipment
- Never insert or disconnect the power plug with wet hands. Doing so may result in severe shock.
- Take care not to push your hand or finger against the manual cutter. Doing so may injure your hand or finger.
 - * When you remove printed paper
 - * When you perform other operations such as loading/replacing roll paper

Caution Labels

The caution labels on the product indicate the following precautions.



Do not touch the thermal head during or immediately after use. After printing, the thermal head and its surroundings can be very hot.

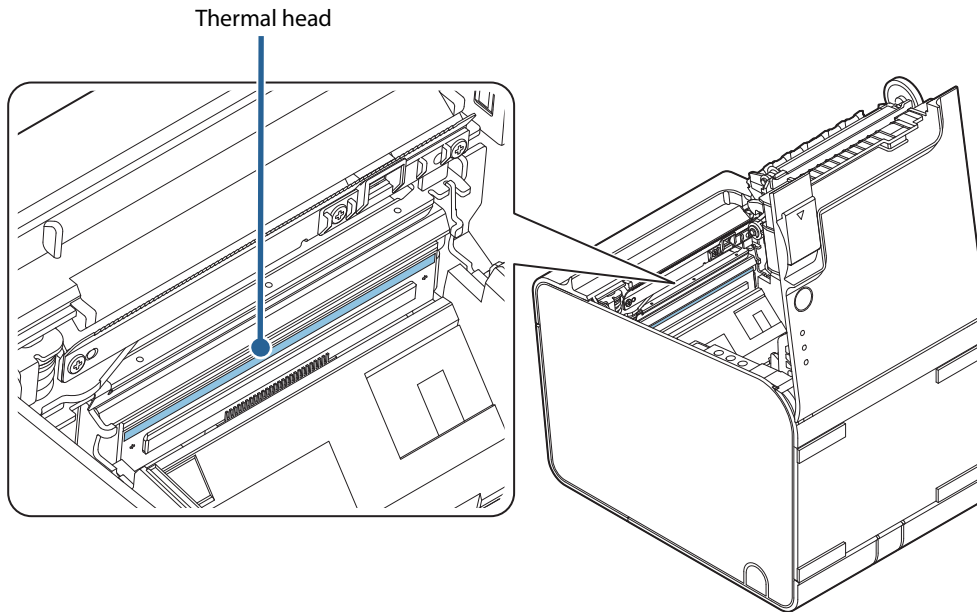

Restriction of Use

When this product is used for applications requiring high reliability/safety, such as transportation devices related to aviation, rail, marine, automotive, etc.; disaster prevention devices; various safety devices, etc.; or functional/precision devices, etc., you should use this product only after giving consideration to including fail-safes and redundancies into your design to maintain safety and total system reliability.

Because this product was not intended for use in applications requiring extremely high reliability/safety, such as aerospace equipment, main communication equipment, nuclear power control equipment, or medical equipment related to direct medical care, etc., please make your own judgment on this product's suitability after a full evaluation.

About this Manual

Aim of the Manual

This manual provides developers/engineers with all the necessary information for design, development and installation of a POS system, and also design and development of a printer application.

Manual Content

The manual is made up of the following sections:

- Chapter 1 [Product Overview](#)
- Chapter 2 [Setup](#)
- Chapter 3 [Advanced Usage](#)
- Chapter 4 [Application Development Information](#)
- Chapter 5 [Handling](#)
- Appendix [Product Specifications](#)
 [Specifications of Interfaces and Connectors](#)
 [Character Code Tables](#)

Contents

■ For Safety	3
Key to Symbols	3
Warnings	3
Cautions	5
Caution Labels	6
■ Restriction of Use	6
■ About this Manual	7
Aim of the Manual.....	7
Manual Content	7
■ Contents	8

Product Overview..... 11

■ Features	11
■ Product Configurations	12
Models	12
Identification of LAN interface models	12
Accessories.....	13
■ Part Names and Functions	14
Front	14
Control Panel.....	15
Connectors.....	16
Online and Offline	17
■ Status and Errors	18
Automatically Recoverable Errors.....	18
Recoverable Errors.....	18
Unrecoverable Errors.....	19
Status Display.....	20
■ NV Memory	21
NV Graphics Memory	21
User NV Memory	21
Memory Switches (Customized Value)	21
User-defined page.....	21
Maintenance Counter	21

Setup 23

■ Flow of Setup	23
■ Installing the Printer	24
■ Changing the Paper Width	25
Removing the Roll Paper Guide	26
Installing the Roll Paper Guide	27
■ Connecting the AC Adapter	29

AC Adapter Connection Procedure	29
---------------------------------------	----

■ **Connecting the Printer to the Host** 31

USB Interface	31
Ethernet Interface	31
For Serial Interface Models	32

■ **Connecting the Cash Drawer** 33

Cash Drawer Requirements.....	33
Connecting the Drawer Kick Cable.....	35

■ **Connecting the Optional Wireless LAN Unit**..... 36

Advanced Usage 37

■ **Software Settings**

Memory Switch 1	39
Memory Switch 2	39
Memory Switch 6	40
Memory Switch 8	41
Customized value	42
Communication condition of serial interface.....	47

■ **Setting/Checking Modes**

Self-test Mode	50
NV Graphics Information Print Mode.....	51
Software Setting Mode.....	52
Starting Hexadecimal Dumping Mode	54

Application Development Information 57

■ **Controlling the Printer**

ePOS-Print XML.....	57
ESC/POS.....	57

■ **Controlling the Cash Drawer**

■ **Software**

Development Kits	59
Drivers	60
Utilities	60
Download	61

Handling..... 63

■ **Installing and Replacing Roll Paper**

■ **Removing Jammed Paper**

■ When the Roll Paper Cover Cannot be Opened	67
■ Cleaning the Printer	68
Cleaning the Printer Case	68
Cleaning the Inside of the Printer	68
■ Preparing for Transport	70

Appendix 71

■ Product Specifications	71
Printing Specifications	73
Character Specifications	74
Details of Characters Per Line and Character Specifications with Auto Scaling Enabled	76
Paper Specifications	83
Printable Area	88
Printing and Cutting Positions.....	90
Electrical Characteristics	91
Environmental Conditions	92
External Dimensions and Mass.....	93
■ Printing and Cutting Positions With Software Setting	94
■ Specifications of Interfaces and Connectors	100
RS-232 Serial Interface	100
USB (Universal Serial Bus) Interface	103
■ Character Code Tables.....	104



Product Overview

This chapter describes features and specifications of the product.

Features

Printing

- Printing on liner-free label paper
- High speed receipt printing (170 mm/s maximum).
- Supports the maximum paper width of 80 mm, and paper width of 40 mm or 58 mm by using the roll paper guide*

* For 65* model, paper width of 80/40mm only supported

Handling

- Horizontal and vertical installation layouts are selectable.
- Easy drop-in paper loading
- Cable connectors can be stored inside the printer.

68* model only

- Paper taken sensor can detect that issued label is taken before issuing the next paper.
- The back-feed function has enabled top margin scaling.

Software

- Command protocol is based on the ESC/POS Proprietary Command System.
- Various layouts are available by using the page mode.
- A maintenance counter function is supported.

Environment

- Paper reduction function is available.

Others

- The interface is selectable.
- A built-in USB interface is also available.

Product Configurations

The installed functions and the included accessories differ depending on the model.

Models

TM-L90 Liner-Free Label Paper Model has the following specifications with different functions.

- 65* model: Paper width of 40/80 mm supported
- 66* model: Paper of 40/58/80 mm supported
- 67* model (multilingual): Paper width of 40/58/80 mm supported
- 68* model (ANK/multilingual): Paper width of 40/58/80 mm supported, paper taken sensor installed, back-feed function installed

Identification of LAN interface models

TM-L90 has LAN interface models as shown below. To check the technical reference guide for the interface board specifications and how to set the network, see the technical reference guide shown below.

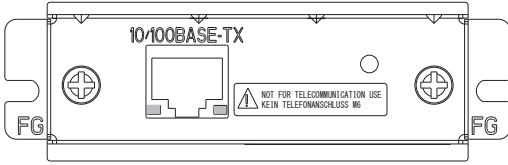
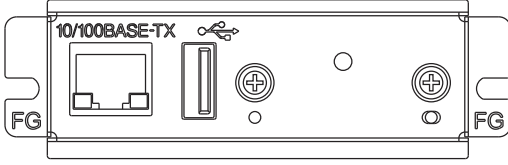
Interface Board		Interface	
External View	Name	Ethernet	Wireless LAN
	UB-E03	✓	-
	UB-E04	✓	✓*

*: For details, see the technical reference guide for the interface board.

Accessories

Included

- Control panel label for vertical installation*
- Roll paper spacer*
- AC adapter*
- AC cable*
- Manuals and documents

* Not included with some models

Options

- Affixing tape for fixing the printer (Model: DF-10)
- Wall hanging bracket (Model: WH-10)
- Wireless LAN Unit

Part Names and Functions

Front

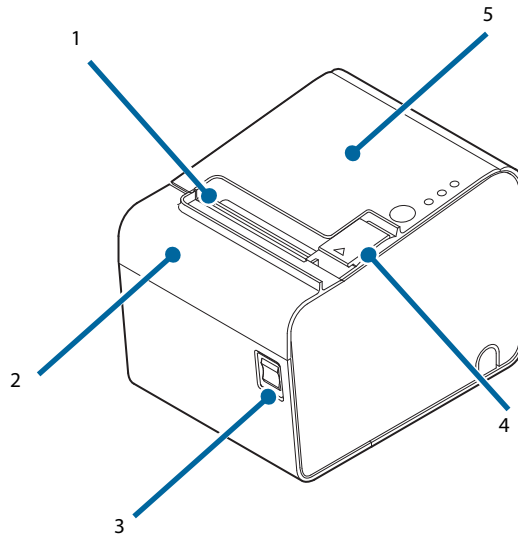





1	Manual cutter	Use this cutter when you cut the roll paper manually.
2	Cutter cover	If the roll paper cover will not open due a paper jam, open this cover and unlock the autocutter blade.
3	Power switch	Turn on/off the printer.
4	Cover open lever	Operate this lever to open the roll paper cover.
5	Roll paper cover	Open this cover to install/replace the roll paper.

CAUTION

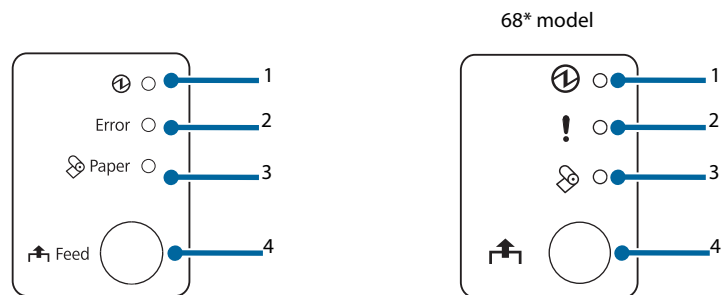
Before turning the printer off, it is recommended to send a power-off command to the printer. If you use the power-off sequence, the latest maintenance counter values are saved. (Maintenance counter values are usually saved every two minutes.) For information about ESC/POS commands, see the ESC/POS Command Reference.

Control Panel



1	 LED	<ul style="list-style-type: none"> • On when the power supply is on. • Off when the power supply is off. • Flashes during the network startup process after power-on and power-off standby status, and while updating firmware.
2	 (Error) LED	<ul style="list-style-type: none"> • Lights or flashes when the printer is offline. • Lights after the power is turned on or after a reset (offline). Automatically goes out after a while to indicate that the printer is ready. • Lights or flashes when an error occurs. (For information about the indication patterns, see "Status and Errors" on page 18.) • Off when the printer is in standard mode (online).
3	 (Paper) LED	<ul style="list-style-type: none"> • Lights when there is no more roll paper. • Flashes to prompt the user to operate the Feed button. 68* model only: Flashes to prompt the user to remove the issued paper and to operate the Feed button.
4	 (Feed) button	<p>Press this button to feed the roll paper by one line. Hold down this button to feed the roll paper continuously.</p> <p>When using liner-free label paper, and while waiting for the issued paper to be removed (for 68* model only), the button operation is disabled.</p>

NOTE

- Attach the control panel label for vertical installation when vertical installation is used. The control panel label for vertical installation is upside down. (["Installing the Printer"](#) on page 24)
- The Feed button is also located inside the roll paper cover. (See ["Software Setting Mode"](#) on page 52)

Connectors

All connectors are located on the bottom of the printer. Different interfaces are used depending on the printer model to be used.

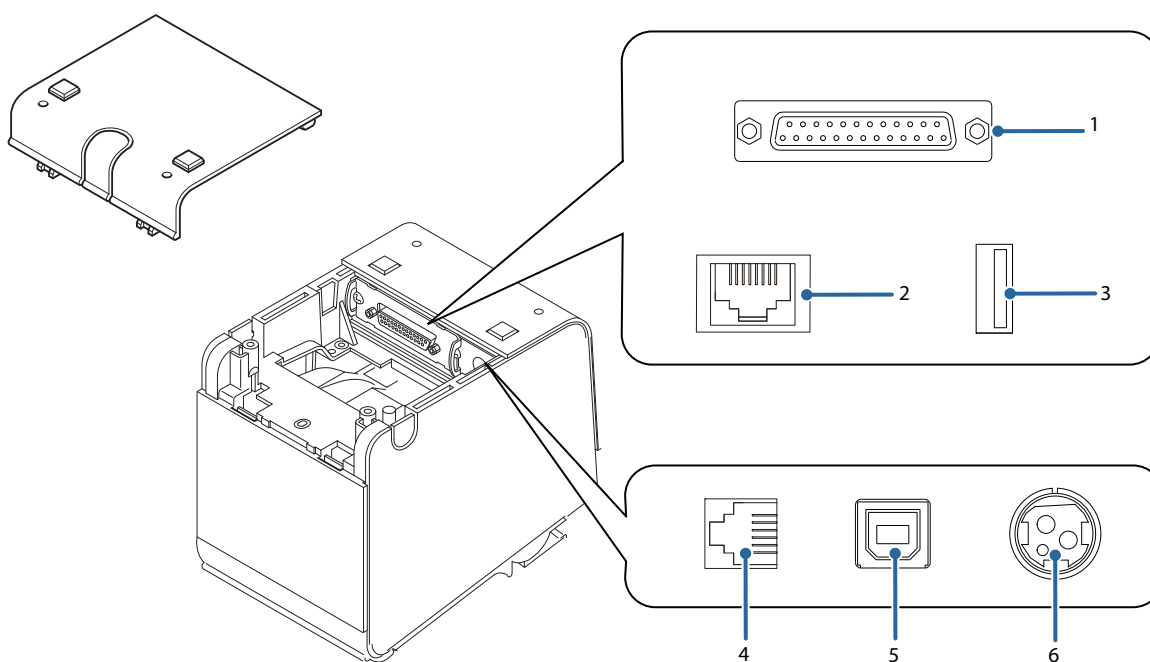

1	Serial interface	Connects the serial cable for connecting to a computer.
2	LAN connector	Connects the 10BASE-T/100BASE-TX Ethernet cable.
3	USB connector	Used only for connecting optional Wireless LAN unit and customer display.
4	Drawer kick connector	Connects the cash drawer or the optional external buzzer. "Connecting the Cash Drawer" on page 33
5	USB connector	Connects the USB cable for connecting to a computer.
6	Power supply connector	Connects the AC adapter. "Connecting the AC Adapter" on page 29

CAUTION

The USB (Type A) interface is used only for connecting the optional Wireless LAN unit.

NOTE

For details about the connection procedures, see ["Connecting the Printer to the Host" on page 31](#), ["Connecting the AC Adapter" on page 29](#), and ["Connecting the Cash Drawer" on page 33](#).

Online and Offline

Online

The printer is online and ready for normal printing unless there is a reason to go offline.

Offline

The printer automatically goes offline under the following conditions:

- While the printer power is turning on/off
- While setting/checking mode is being executed (excluding hexadecimal dumping mode)
- While roll paper is fed using the Feed button
- When the printer stops printing due to a paper end (when the paper out detector detects that there is no paper)
- During an operation standby state
- When an error has occurred ("[Status and Errors](#)" on page 18)
- While the roll paper cover is open

Status and Errors

The LEDs light or flash to indicate the printer status.

<div style="border: 1px solid black; padding: 2px; display: inline-block;">NOTE</div>	The printer cannot print while an error is left unresolved.
--	---

Automatically Recoverable Errors

The printer cannot print when automatically recoverable errors occur. It can be recovered as described below.

Error	Error description	Error LED flash code	Condition for Recovery
Roll paper cover open error*	The roll paper cover was opened while printing.		Recovers automatically when the roll paper cover is closed.
Head temperature error	A high temperature outside the head drive operating range was detected.		Recovers automatically when the print head cools.

*: When the memory switch 8-8 is set to OFF (Roll paper cover open while the printer is printing: automatically recoverable error)

Recoverable Errors

The printer cannot print when a recoverable error occurs. It can be recovered easily by turning the power on again or sending an error recovery command from the driver after eliminating the cause of the error.

Error	Error description	Error LED flash code	Condition for Recovery
Roll paper cover open error*	The roll paper cover was opened while printing.		Recovers when the roll paper cover is closed and the error recovery command is executed or the power is turned on again.

Error	Error description	Error LED flash code	Condition for Recovery
Autocutter error	The Autocutter does not work correctly.		Recovers when the jammed paper or foreign matter is removed and the roll paper cover is closed, and then the error recovery command is executed or the power is turned on again.

*: When the memory switch 8-8 is set to ON (Roll paper cover open while the printer is printing: recoverable error)

<div style="border: 1px solid black; padding: 2px; display: inline-block;">NOTE</div>	The error recovery command is valid only if a recoverable error (excluding automatically recoverable errors) occurs.
--	--

Unrecoverable Errors

The printer cannot print when an unrecoverable error occurs. If the error persists after turning the printer off and then on again, the printer may be defective. Contact qualified service personnel.

CAUTION	Turn off the power immediately when an unrecoverable error occurs.
----------------	--

Error	Error description	Error LED flash code
R/W error in memory	After R/W checking, the printer does not work correctly.	
High voltage error	The power supply voltage is extremely high.	
Low voltage error	The power supply voltage is extremely low.	
CPU execution error	The CPU is executing an incorrect address.	
Internal circuit connection error	Internal circuits are not connected correctly.	

Error	Error description	Error LED flash code
Interface error	Interface error	

Status Display

	LED	Error LED	PaperLED
Online	ON	OFF	OFF
Initializing after power-on	ON	ON	-
Running a self-test	ON	OFF	-
Waiting to continue self-test	ON	OFF	Flashing
Feeding using the Feed button	ON	OFF	-
Waiting to execute a macro	ON	OFF	Flashing
Roll paper cover open while the printer is not printing	ON	ON	-
No paper	ON	ON	ON
Near end	ON	OFF	ON
While updating firmware	Flashing	OFF	OFF
In power off standby status	Flashing	OFF	OFF
Waiting to print status sheet	ON	ON	Flashing
68* model only: Paper removal standby	ON	OFF	Flashing

-: Changes depending on whether or not paper is detected.

NV Memory

The printer is equipped with NV memory (Nonvolatile Memory) to store data even after the printer power is turned off. NV memory contains the following memory areas for the user:

- NV graphics memory
- User NV memory
- Memory switches
- User-defined page
- Maintenance counter

CAUTION

As a guide, NV memory rewriting should be 10 times or less a day when you program applications.

NV Graphics Memory

Graphics, such as shop logos to be printed on receipts, can be stored. Even with a serial interface model whose transmission speed is low, high speed graphic printing is possible.

Use the TMFlogo logo registration utility to register graphics.

User NV Memory

You can store and read text data for multiple purposes, such as for storing a note including customizing or maintenance information of the printer.

Memory Switches (Customized Value)

You can configure the serial interface communication conditions and other various settings of the printer. For more information, see ["Software Setting Mode" on page 52](#).

User-defined page

You can store character data in the user-defined page (character code table: page 255) so that you can also print characters not resident in the printer.

Maintenance Counter

With this function, printer information, such as the number of lines printed, the number of autocuts, and printer operation time after the printer starts working, is automatically stored in NV memory. You can read the counter information with the Status API of the APD, OPOS ADK, or ESC/POS commands. You can use the counter information for periodical checks or part replacement.



Setup

This chapter describes setup and installation of the product and peripherals.

Flow of Setup

This chapter consists of the following sections along with the setup flow of the product and peripherals.

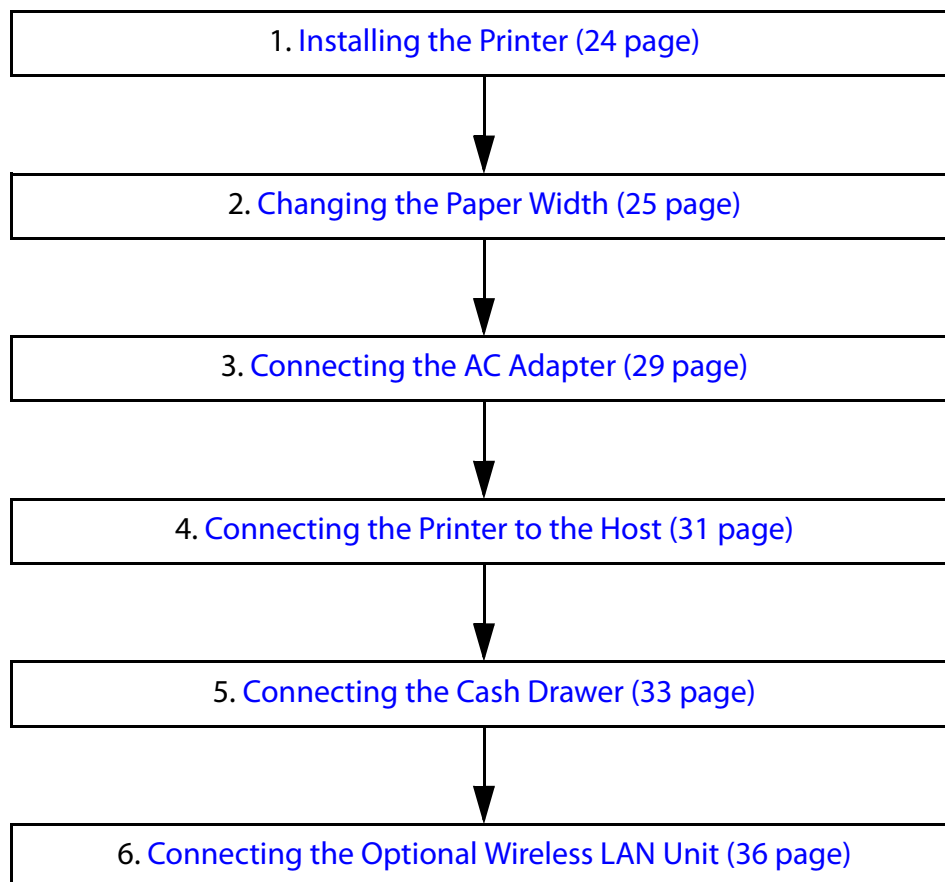

Installing the Printer

You can install the printer horizontally on a flat surface (with the paper exit on top) or vertically (with the paper exit at the front). Also, you can hang it on a wall using the optional wall hanging bracket (WH-10). Attach the control panel label for vertical installation when vertical installation (with the paper exit at the front) is used.

<Horizontal installation>

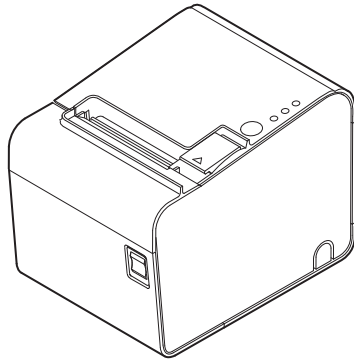

<Vertical installation>

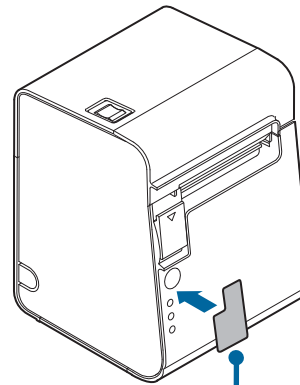

Control panel for vertical installation

CAUTION

- Do not place the printer in a dusty location.
- Do not knock or strike the printer. Doing so may cause defective printing.
- Be careful not to catch cables or place foreign matter under the printer during installation.

Changing the Paper Width

Install/remove the roll paper guide according to the roll paper width to be used.

The width of the installed roll paper guide differs according to the model by factory default.

❑ 65* model

Equipped with the 40 mm roll paper guide.

- When using 40 mm width roll paper, use this guide.
- When using 80 mm width roll paper, remove the installed guide.

❑ 66*/67*/68* models

Equipped with the 58 mm roll paper guide.

- When using 58 mm width roll paper, use this guide.
- When using 80 mm width roll paper, remove the installed guide.
- When using 40 mm width roll paper, remove the installed guide and install the guide for 40 mm paper supplied with the product.

NOTE

- Because some parts of the print head and the autocutter blade may contact the platen and become worn out, you cannot change a smaller paper width to a larger one once you start using the product.
- The printable area is automatically defined by detecting the installed roll paper guide. However, to change the paper width from 58 mm to 40 mm, using the memory switch is required. ("[Memory Switch 6](#)" on page 40)

Removing the Roll Paper Guide

- 1 Press the cover open lever to open the roll paper cover.

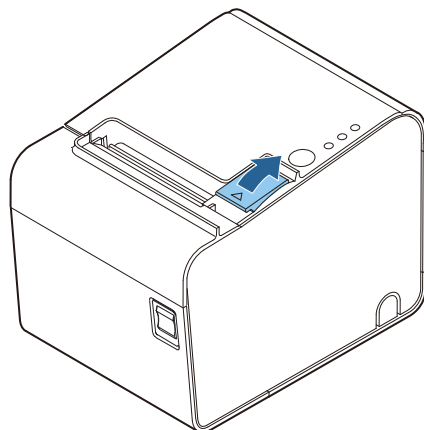

- 2 While pushing down the roll paper guide lever in the arrow direction, lift the whole roll paper guide to remove it.

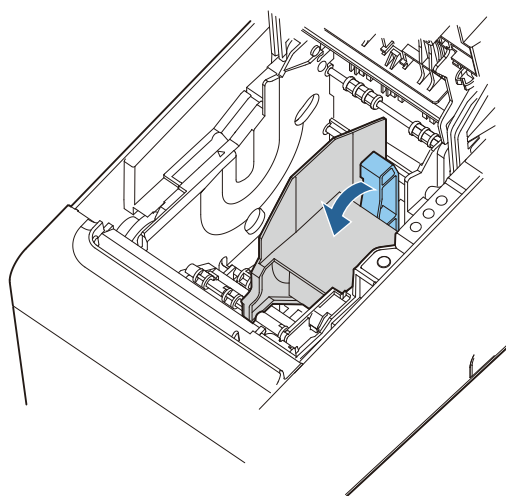

Installing the Roll Paper Guide

- 1 Press the cover open lever to open the roll paper cover.

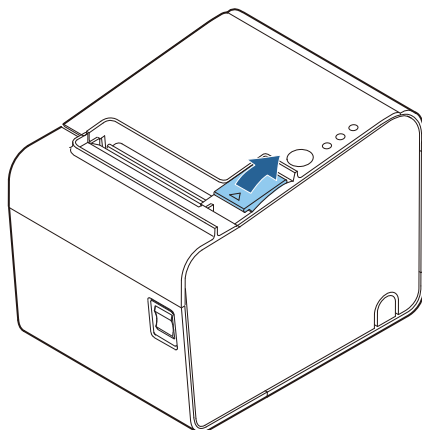

- 2 Install the roll paper guide inside the printer.
Align the guide with the holes, cutouts, and protrusions in the printer as shown below. The installation position of the roll paper guide is different depending on the width of the roll paper guide.

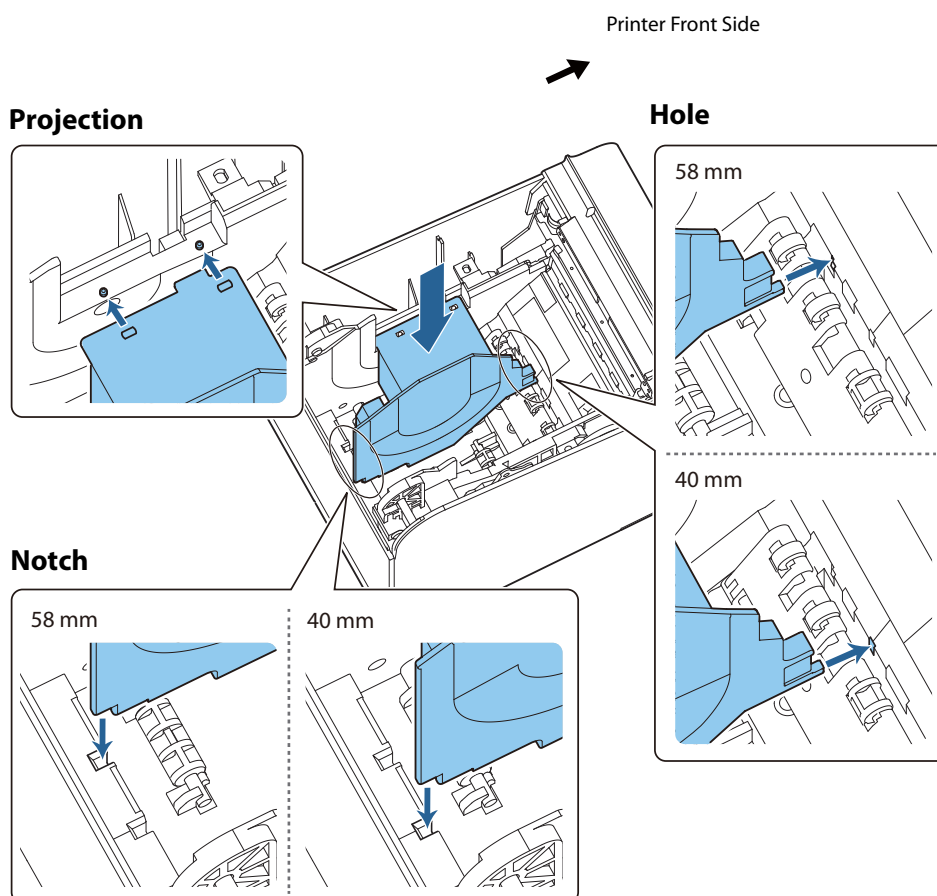

-
- 3** Push the lever of the roll paper guide down until the paper guide clicks into place.

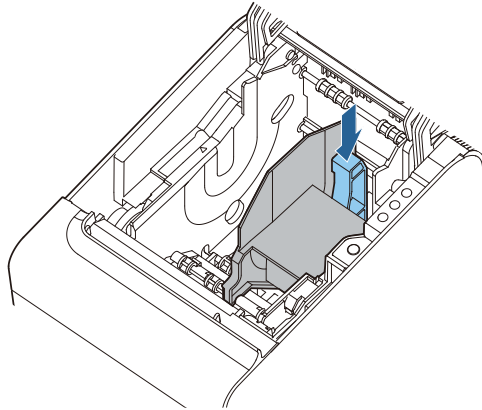

Connecting the AC Adapter

For the AC adapter, use PS-180 or the equivalent.
Use the AC cable supplied with the product.



WARNING

- Use of an unspecified AC adapter may cause fire or electrical shock.
- Should a fault ever occur, immediately turn off the power to the printer and unplug the AC cable from the wall socket.

AC Adapter Connection Procedure

- 1 Make sure the printer is turned off.
- 2 Remove the cover on the rear side of the printer.

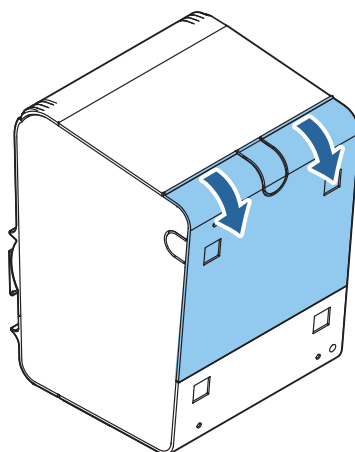

- 3 Connect the DC cable of the AC adapter to the power supply connector (stamped DC 24V).

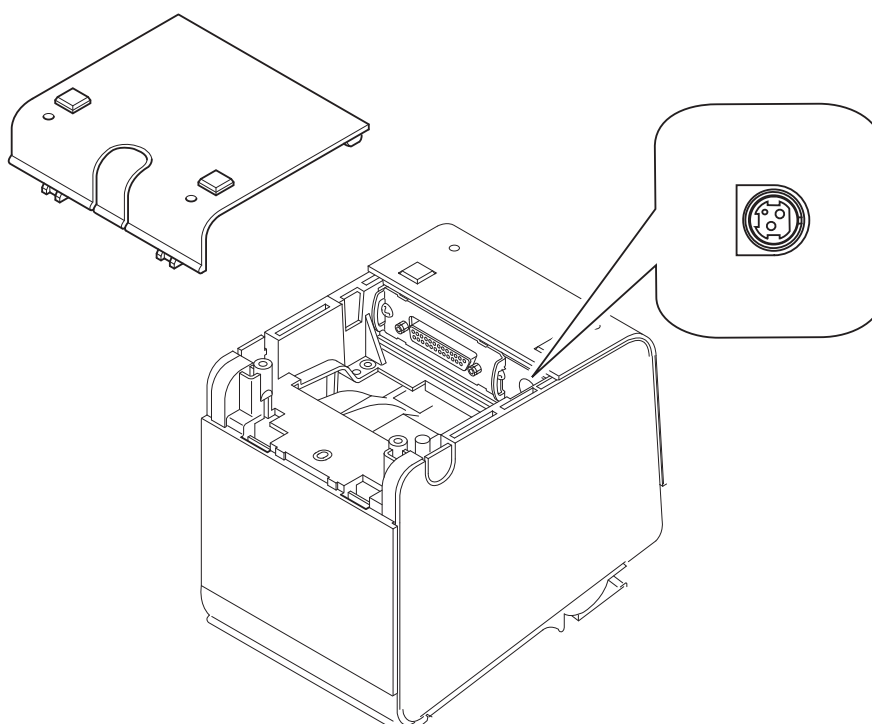

- 4 Remove any of the knockouts (at 3 locations) on the rear cover and pass the cable through.

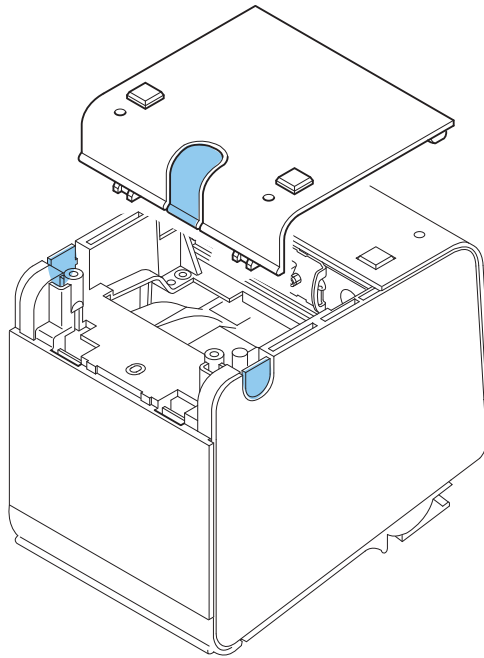

- 5 Close the rear cover.
- 6 Connect the AC cable to the AC adapter.
- 7 Connect the AC cable to the power outlet.

CAUTION

Before disconnecting the DC cable of the AC adapter from the printer, make sure that the AC cable is disconnected. Then, hold the arrow part of the connector and pull out the cable while keeping it straight.

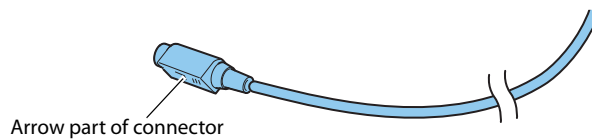

Connecting the Printer to the Host

CAUTION

The printer uses a modular connector specifically designed for the cash drawer or for the customer display. Do not connect these connectors to an ordinary telephone line.

USB Interface

When using USB cable to connect with host device, connect the USB cable to the printer, and after starting the host device, turn the printer on.

CAUTION

- Do not place any weight or stress on the cable when using. Doing so could damage the cable and connectors.
- To prevent disconnection of the USB cable, secure the cable to the hook on the locking wire saddle as shown below.

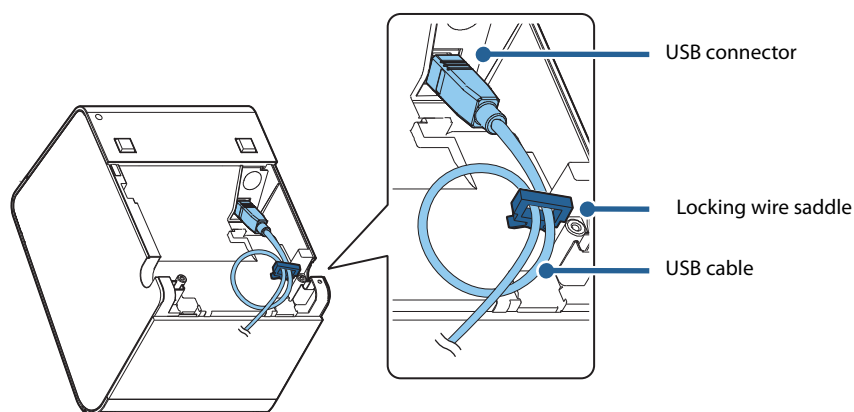

Ethernet Interface

Use an Ethernet cable to connect the printer to a network via a hub.

Use Epson EpsonNet Config to set network. For details about EpsonNet Config, refer to EpsonNet Config Operations Guide.

CAUTION

- When LAN cables are installed outdoors, make sure they are connected through devices that have surge protection. Otherwise, the devices can be damaged by lightning.
- Never attempt to connect the customer display cable, the drawer kick cable, or a telephone line cable to the LAN connector.

NOTE

As same with Conventional models, you can use EpsonNet Config (Web version) in the same way.
User name/password: epson

For Serial Interface Models

CAUTION

Use Epson's optional cable or the equivalent.

- Crossover cable for RS-232C interface 2 m(model: OI-C01)
D-sub 9-pin (female) connector -D-sub 25-pin (male) connector

When connecting to the host computer through a serial interface (RS-232), connect a serial cable to the printer, start the host computer, and then turn on the printer.

NOTE

- When using connectors equipped with screws, tighten the screws on both sides to secure the connectors firmly.
- When using interface cables equipped with a ground line, attach the ground line to the screw hole marked "FG" on the printer.

Connecting the Cash Drawer

CAUTION

- Two driver transistors cannot be energized simultaneously.
- Leave intervals longer than 4 times the drawer driving pulse when sending it continuously.

Cash Drawer Requirements

Specifications of drawers greatly differ depending on manufacturers and models. When you use a drawer other than specified, make sure its specification meets the following conditions. Otherwise, devices may be damaged.

- The load, such as a drawer kick solenoid, must be connected between pins 4 and 2 or pins 4 and 5 of the drawer kick connector.
- When the drawer open/close signal is used, a switch must be provided between drawer kick connector pins 3 and 6.
- The resistance of the load, such as a drawer kick solenoid, must be 24 ohms or more or the input current must be 1 A or less.
- Be sure to use the 24 V power output on drawer kick connector pin 4 for driving the equipment.

2

Drawer Connection Diagram

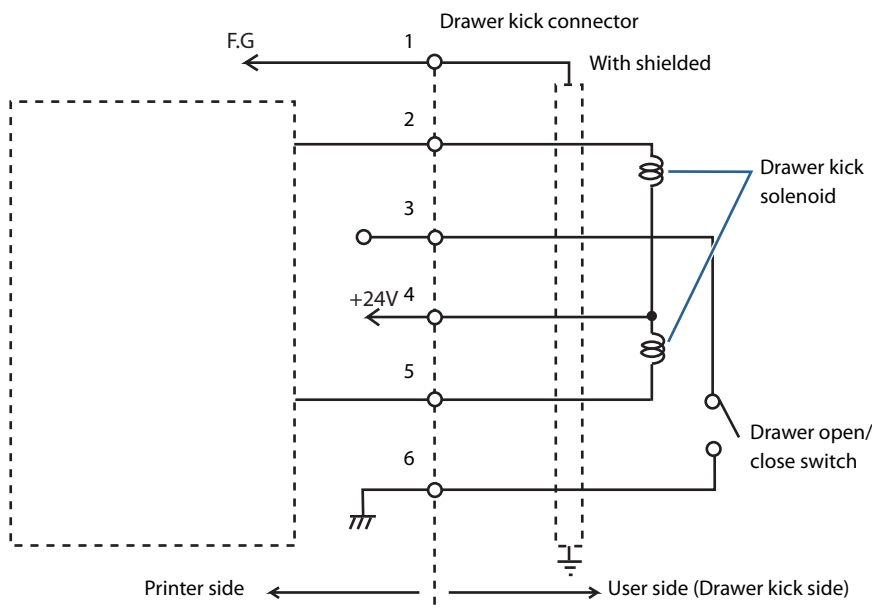

Connector

Modular connector RJ12

Pin assignments

Pin number	Signal name	Direction
1	Frame GND	-
2	Drawer kick drive signal 1	Output
3	Drawer kick open/close signal	Input
4	+24 V	-
5	Drawer kick drive signal 2	Output
6	Signal GND	-

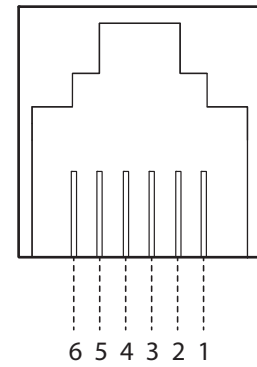

Connecting the Drawer Kick Cable



WARNING

- Use a shield cable for the drawer kick cable.
- When using cash drawer, make sure to use the power supply for printer (connector pins 4).
- Do not insert a telephone line into the drawer kick connector.
- Doing so may damage the telephone line or printer.

Connect the drawer kick cable to the drawer kick connector by pressing firmly until the connector clicks into place.

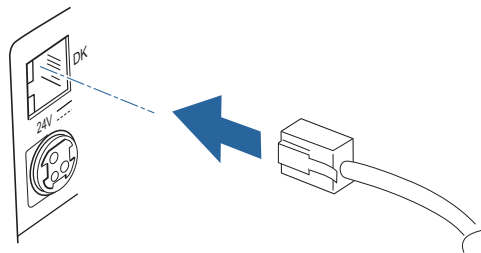

Connecting the Optional Wireless LAN Unit

The optional Wireless LAN cable set enables you to use the product with a Wi-Fi connection. For more information, refer to User's Manual of the Wireless LAN cable set.

CAUTION

- Be sure to turn off the printer when connecting the Wireless LAN unit.
- Depending on the installation conditions of the printer and the routing for cables connected to it, the status of the radio waves for the Wireless LAN unit may decline. If this does happen, use an extension cable.

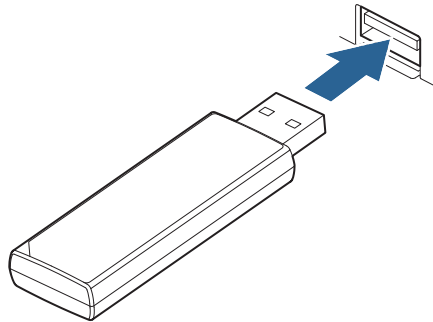

Advanced Usage

Software Settings

With the functions such as the memory switches and customized values, which are software settings for this printer, you can set the various functions.

For an outline of the functions, see the following pages. Use the software setting mode or the memory switch setting utility for setting the functions.

NOTE

- In the software setting mode, panel operations on the printer are used to configure settings. For details about the panel operations, see "[Software Setting Mode](#)" on page 52.
- For information about how to use the memory switch setting utility, see the User's Manual for the memory switch setting utility.
- For information about ESC/POS commands, see the ESC/POS Command Reference.
- To check the setting status, use the self-test ("[Self-test Mode](#)" on page 50) or the memory switch setting utility.

Item/Method		Software Setting Mode	Memory Switch Setting Utility
Memory Switches	1	Transmission of the power ON information	✓
		Capacity of receive buffer	✓
		Condition for BUSY	✓
		Data receive error	
		Automatic line feed	✓
	2	Autocutter operation	✓
	6	Autocutting position	✓
		Auto scaling for 40/58 mm width paper	✓
		Auto top margin scaling	✓
		Selection of the characters per line for 80 mm width paper	✓
		Selection of paper width	✓
	8	Enable left or right margin of bar code print	
		Roll paper cover open during operation	

Item/Method		Software Setting Mode	Memory Switch Setting Utility
Customized value	User NV memory capacity setting		✓
	NV graphics memory capacity setting		✓
	Selection of the energization parting		✓
	Selection of printing density	✓	✓
	Selection of print speed	✓	✓
	Automatic Paper Reduction	✓	✓
	Auto image data scaling	✓	✓
	Selection of the media type detection method*	✓	✓
	Amount of top margin by backfeed*	✓	✓
	Stop position when Label cutting*	✓	✓
	Selection of paper removal standby*	✓	✓
Serial interface communication condition setting		✓	✓

* *: 68* model only

Memory Switch 1

SW	Function	ON	OFF
1-1	Transmission of the power ON information	Transmits	Does not transmit
1-2	Capacity of receive buffer	45 bytes	4 KB
1-3	Condition for BUSY	Receive buffer full	Receive buffer full or Offline
1-4	Data receive error	Ignored	Prints "?"
1-5	Automatic line feed	Enabled	Disabled
1-6 to 1-8	Reserved	—	—

CAUTION

- Regardless of the settings for memory switches 1-3, the printer enters the BUSY state after the power is turned on (including the reset using the interface), and when a self-test is being run.
- If the memory switches 1-3 are set to ON, the printer will not become BUSY in the following cases:
 - * When the roll paper cover is open
 - * When paper is fed by the FEED button
 - * When printing has stopped due to paper out
 - * When macro execution ready state
 - * When error has occurred

Memory Switch 2

SW	Function	ON	OFF
2-1	Reserved (Do not change the setting)	Fixed to On	
2-2	Autocutter operation	Enabled	Disabled
2-3 to 2-8	Reserved	—	—

Memory Switch 6

SW	Function	ON	OFF
6-1	Autocutting position	Cut at black mark position	Cut regardless of black mark position
6-2	Auto scaling for 40/58 mm width paper ^{*1}	Enabled	Disabled
6-3	Auto top margin scaling ^{*2}	Enabled	Disabled
6-4	Selection of the characters per line for 80 mm width paper ^{*3}	See the table below.	
6-5		"Selection of the characters per line for 80 mm width paper (compatible mode)" on page 40	
6-6 to 6-7	Reserved	—	—
6-8	Paper width selection ^{*4}	58 mm/80 mm	40 mm/80 mm

*1: For details about the characters per line and character specifications with this function enabled, see "Details of Characters Per Line and Character Specifications with Auto Scaling Enabled" on page 76.

*2: Enabled when printing continues after autocutting.

To set the function using the software setting mode, select [11. Top margin reduction] - [11.2 when Paper removal standby is invalid].

3: With the 67/68*(multilingual) models, the functions for the memory switches 6-3/6-4/6-5 are reserved and unavailable.

4: With the 65 model, the function for memory switch 6-8 is reserved and unavailable.

Selection of the characters per line for 80 mm width paper (compatible mode)

Compatible mode		TM-T88 compatible mode (1)	TM-T88 compatible mode (2)	TM-L90 compatible mode
Characters per line	Font A	42	44	48
	Font B	55	57	64
Memory Switch 6	6-4	ON	ON	OFF
	6-5	ON	OFF	OFF

NOTE

The printing and autocutting positions change depending on the software setting. For details, see "Printing and Cutting Positions" on page 90.

Memory Switch 8

SW	Function	ON	OFF
8-1 to 8-4	Reserved	—	—
8-5	Enable left or right margin of bar code print	Enables margin	Does not enable margin
8-6	Reserved	—	—
8-7	Reserved	—	—
8-8	Roll paper cover open while the printer is printing	Recoverable errors	Automatically recoverable errors

Customized value

User NV memory capacity setting

- 1 KB (default setting)
- 64 KB
- 128 KB
- 192 KB

NV graphics memory capacity setting

The memory area for NV graphics data and the user NV memory area use a common area. Therefore, the memory capacity that can be set for NV graphics changes depending on the user NV memory capacity setting. If the specified memory capacity for NV graphics is out of the allowable range, the capacity is automatically changed to a value that can be set.

Capacity of the user NV memory	Capacity of the NVgraphics
1 KB	<ul style="list-style-type: none">• None• 64 KB• 128 KB• 192 KB• 256 KB• 320 KB• 384 KB (default setting)
64 KB	<ul style="list-style-type: none">• None• 64 KB• 128 KB• 192 KB• 256 KB
128 KB	<ul style="list-style-type: none">• None• 64 KB• 128 KB
192 KB	<ul style="list-style-type: none">• None

Selection of the energization parting

- One-part energizing (default setting)
- Two-part energizing
- Three-part energizing
- Four-part energizing

NOTE

- In normal operation, there is no need to change the energization parting.
- The maximum print speed is available only in the one-part energizing mode.
- Four-part energizing mode can reduce power consumption.

Selection of printing density

Models	Media type	Density setting	Default setting
Other than the 68* model	Thermal paper	100 - 130% (in increments of 5%)	120%
	Liner-free label paper	Fixed	Fixed
68* model	Thermal paper	100 - 130% (in increments of 5%)	120%
	Liner-free label paper	75 - 100% (in increments of 5%)	100%

Depending on the paper type, it is recommended to set the print density as shown in the table below for the best print quality.

Thermal paper (without black marks):

Original Paper type	Density
P35524, P30523, P31523	120%
TF50KS-EY, F5041(55), KT55FA, KT48FA	115%
AF50KS-E	110%
KF50	100%

Liner-free label paper (with black marks):

Original Paper type	Density Other than the 68* model	Density 68* model
9023-1274, 9023-1253 (Lane coated: 80 mm)	Fixed	100%
9023-1823, 9023-1397 (Lane coated: 58 mm)	Fixed	100%
9023-1275, 9023-1257 (Lane coated: 40 mm)	Fixed	100%

NOTE

When the print density level is increased, print speed may be reduced.

Selection of print speed

Selectable from levels 1 to 11 (Slow – Fast)

Default setting: level 6

NOTE

- Printing speed may be slower, depending on items such as the print data, head temperature, and energization parting.
- If white lines are caused by intermittent printing (printing sometimes stops) in graphics printing, etc., set the print speed at low speed or, for serial interface models, set the communication speed at high speed to prevent white lines.

Automatic Paper Reduction

Reduction of top margin

- Does not reduce
- Reduces

Reduction of bottom margin

- Does not reduce
- Reduces

Reduction of line spacing

- Does not reduce
- Reduces 25%
- Reduces 50%
- Reduces 75%
- Reduces the most (68* model only)

Reduction of line spacing where extra line feeds are included

- Does not reduce
- Reduces 25%
- Reduces 50%
- Reduces 75%

Reduction of bar code heights

- Does not reduce
- Reduces 25%
- Reduces 50%
- Reduces 75%

Reduction ratio of character height (68* model (ANK) only)

- Does not reduce
- Reduces 25%
- Reduces 50%
- Reduces 75%
- Reduces 75% and shortens character height
- Reduces the most and shortens character height

NOTE

- The printing and autocutting positions change depending on the paper type or the software setting. ("[Printing and Cutting Positions With Software Setting](#)" on page 94)
- Some selections are unavailable in the self-test mode. Use the memory switch setting utility.

Auto image data scaling

- Nearest neighbor interpolation: Shrink the image data by 82%, keeping the aspect ratio.
- Cut off both sides: Cut off 46 dots from the edge of both sides of the image data.
- Cut off the right side: Cut off 92 dots from the right side of the image data.
- Cut off the left side: Cut off 92 dots from the left side of the image data.
- None: Actual size image data is defined or printed

NOTE

- This function has the following restrictions:
 - * The print-start time will be late.
 - * The print-result may have a blank line.
- This function is not available, if the data is less than 92 dots.

Selection of the media type detection method

- Auto detection (default setting)
- Fixed to liner-free label paper
- Fixed to continuous paper without black marks

Amount of top margin by backfeed

This function is enabled when the selection of paper removal standby is set to "Enabled".

Selectable from 4.0 to 14.0 mm (in increments of 0.5 mm)

Default setting: 4 mm

NOTE

- The printing and autocutting positions change depending on the paper type or the software setting. ("[Printing and Cutting Positions With Software Setting](#)" on page 94)
- To set the function using the software setting mode, select [11. Top margin reduction] - [11.1 when Paper removal standby is invalid].

Stop position when Label cutting

- Arbitrary stop position (default setting)
- Specific stop position

NOTE

The printing and autocutting positions change depending on the paper type or the software setting. ("[Printing and Cutting Positions With Software Setting](#)" on page 94)

Selection of paper removal standby

- Enabled (default setting)
- Disabled

Communication condition of serial interface

Transmission speed

- 2400 bps
- 4800 bps
- 9600 bps
- 19200 bps (default setting)
- 38400 bps
- 57600 bps
- 115200 bps

[bps: bits per second]

Parity

- No parity (default setting)
- Odd parity
- Even parity

Handshaking

- DSR/DTR (default setting)
- XON/XOFF

Bit length

- 7 bits
- 8 bits (default setting)

Setting/Checking Modes

As well as print mode, the following modes are also provided for making various printer settings and checking items.

- Self-test mode
- NV graphics information print mode
- Software setting mode
- Hexadecimal dumping mode

You can select the mode depending on the operation at power-on.

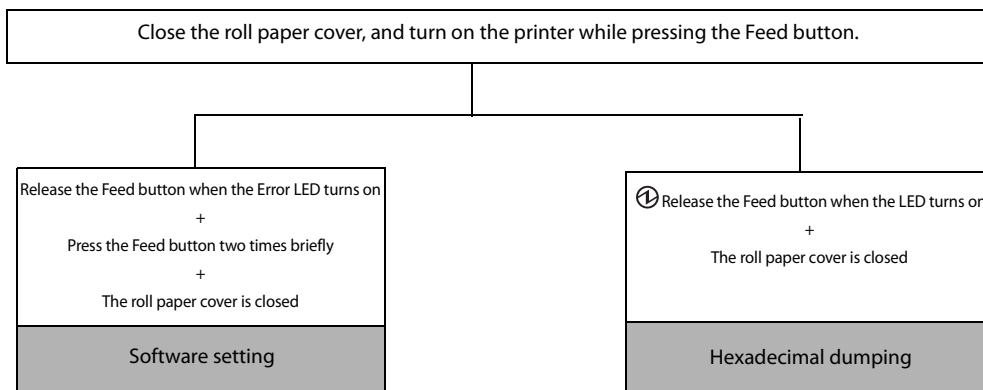
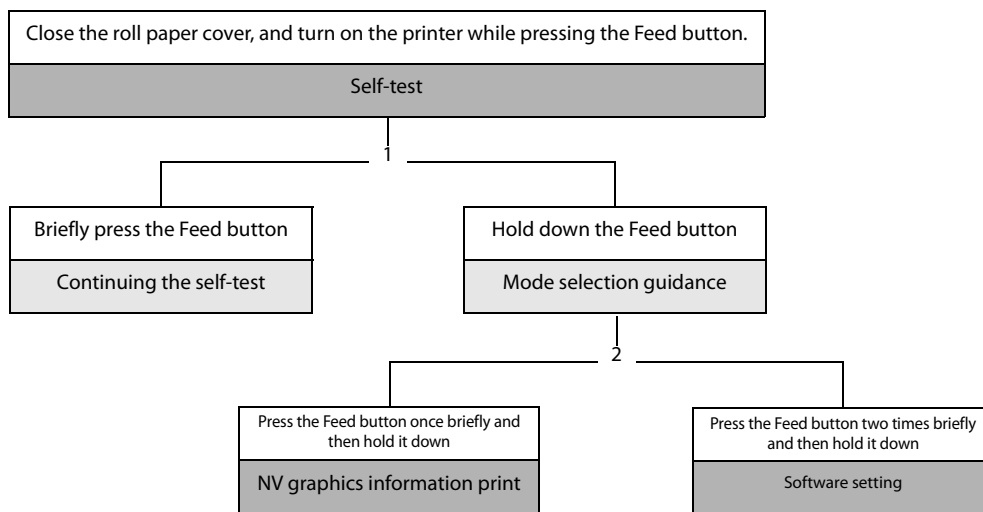

In (1) and (2), the following guidances are printed, the Paper LED flashes, and instructs the user's operations.

1. Continuing self-test guidance

Select Modes by pressing Feed Button.
Continue SELF-TEST: Less than 1 second
Mode Selection : 1 second or more

2. Mode selection guidance

Mode Selection

Modes

- 0: Exit and Reboot Printer
- 1: NV Graphics Information
- 2: Customize Value Settings
- 3: or more: None

Select Modes by executing following procedure.

- step 1. Press the Feed button less than 1 second as many times as the selected mode number.
- step 2. Press Feed button for 1 second or more.

Self-test Mode

In the self-test mode, the printer prints the current printer status and a rolling pattern test print of resident characters.

The current status print includes the following information:

- Control software version
- Serial number
- Interface type
- Receive buffer size
- BUSY condition
- Built-in fonts
- Auto line feed enabled/disabled
- Print density
- Power ON status transmission enabled/disabled
- Paper width to be set
- Media type detection
- Type of paper
- Stop position when Label cutting
- Setting status of paper removal standby
- Various sensor values
- Print speed to be set
- Top margin length
- Maintenance information
- Memory switch settings

Follow the procedures below.

- 1** Close the roll paper cover.
- 2** While pressing the Feed button on the control panel, turn on the printer. (Hold down the Feed button until printing starts.)
After printing the current print status, a Continuing self-test guidance is printed, and the Power LED flashes.
- 3** Briefly press the Feed button (less than one second) to continue the self-test.
The printer prints a rolling pattern on the roll paper, using the built-in character set.
After "**** completed ****" is printed, the printer initializes and switches to standard mode.

NV Graphics Information Print Mode

Prints the following NV graphics information registered to the printer.

- Capacity of the NV graphics
- Used capacity of the NV graphics
- Unused capacity of the NV graphics
- Number of NV graphics that are registered
- Key code, number of dots in X direction, number of dots in Y direction to be defined.
- NV graphics data

NOTE

For details on NV graphics, see ["NV Graphics Memory" on page 21](#).

Follow the procedures below.

- 1** After running a self-test, hold down the Feed button for at least one second to enter the Mode selection.
The Mode selection guidance is printed, and the Paper LED flashes.
- 2** After briefly (less than one second) pressing the Feed button once, hold it down for at least one second, to print the NV graphics information.
After information printing, the Mode selection guidance is printed again.
- 3** To finish, turn off the power, or select "Exit and Reboot Printer".

Software Setting Mode

This mode is used to set the memory switches and the customized values of the printer.

NOTE

- For information about the memory switches, see ["Software Settings" on page 37](#).
- The software setting mode can also be started from the self-test mode. (["Advanced Usage" on page 37](#))

Follow the procedures below.

- 1** Make sure that the roll paper is properly installed and that the printer is turned off.
- 2** Open the roll paper cover.
- 3** While pressing the Feed button in the printer, turn on the printer.
Hold down the Feed button until the Error LED turns on.

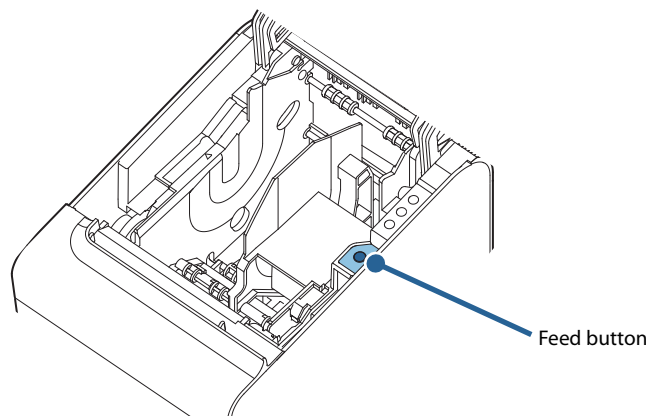

- 4** Release the Feed button when the Error LED turns on.

- 5** Press the Feed button two times and close the roll paper cover.
The operation guidance is printed.

Customize Value Settings

Modes

- 0. Exit
- 1. Print Current Settings
- 2. Print Density
- 3. Serial Interface Settings
- 4. Automatic Paper Reduction
- 7. Printing Speed
- 8. Auto Cut
- 9. Define where to print and cut
- 10. Font size automatic reduction
- 11. Top margin reduction
- 12. Printing digits number
- 13. Other Settings

Select Modes by executing following procedure.

- step 1. Press the Feed button less than 1 second as many times as the selected mode number.
- step 2. Press Feed button for 1 second or more.

- 6** Press the Feed button in the printer the number of times indicated on the print result, and close the roll paper cover.

When one setting has been completed, the printer stores the setting.
For details on setting items, see "[Software Settings](#)" on page 37.

- 7** To exit the software setting mode, turn off the printer.

NOTE

- To select 0 as the item number, hold down the Feed button until printing starts.
- If the button is pressed a number of times that is not displayed by the Setup guidance, the operation is invalid and the same guidance is printed.

Starting Hexadecimal Dumping Mode

In the hexadecimal dumping mode, the printer prints the data transmitted from a host device in hexadecimal numbers and their corresponding characters. It enables you to check if data is transmitted to the printer correctly.

CAUTION

- If there is no character corresponding to print data, "" is printed.
- If you press the Feed button when there is less than one line of print data, one line is printed.
- During hexadecimal dumping mode, applications that check the printer status may not operate correctly. The printer only returns the status for the "Real-time transmission status" command.

Follow the procedures below.

- 1 Open the roll paper cover.
- 2 While pressing the Feed button in the printer, turn on the printer.

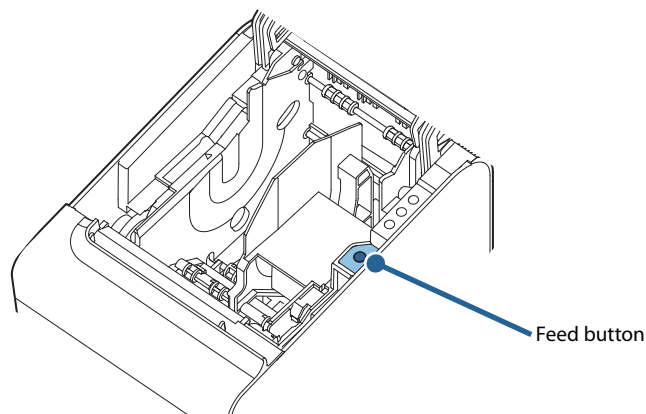

- 3 Close the roll paper cover.
The printer starts printing data received from then on in hexadecimal numbers and their corresponding ASCII characters.

Example of printing in hexadecimal dumping mode

```
Hexadecimal Dump
To terminate hexadecimal dump,
press FEED button three times.

1B 21 00 1B 26 02 40 40 1B 69 . ! . . & . @ @ . i
1B 25 01 1B 63 34 00 1B 30 31 . % . . c 4 . . 0 1
41 42 43 44 45 46 47 48 49 4A A B C D E F G H I J

*** completed ***
```

- 4 To close hexadecimal dumping mode, turn off the printer after printing is complete, or press the Feed button for three times.



Application Development Information

This chapter describes how to control the printer and gives information useful for printer application development.

Controlling the Printer

The printer supports the following command systems:

- ePOS-Print XML (models equipped with UB-E04 only)
- ESC/POS

Users can control the printer by using the aforementioned command, or the following development kits or drivers.

- EPSON Advanced Printer Driver (APD)
- OPOS ADK
- OPOS ADK for .NET
- JavaPOS ADK
- Epson ePOS SDK for JavaScript (models equipped with UB-E04 only)

ePOS-Print XML

ePOS-Print XML is the Epson original control command system for POS printers defined in XML. With ePOS-Print XML commands, you can print in environments where http communication is available and from OS applications. For detailed information about ePOS-Print XML, see the ePOS-Print XML User's Manual.

ESC/POS

ESC/POS is the Epson original printer command system for POS printers and customer display. With ESC/POS commands, you can directly control all the printer functions, but detailed knowledge of printer specifications or combination of commands is required, compared to using drivers and applications. For details of ESC/POS, see the ESC/POS Command Reference. The ESC/POS Command Reference can be accessed at the following URL.
www.epson-biz.com/pos/reference/

Controlling the Cash Drawer

A pulse output is sent to drawer kick connector pin 2 or pin 5, and you can open the drawer. You can also check the open/close status of the drawer by checking the signal level of the drawer kick connector pin 3.

These controls are executed by a driver or by commands.

ESC/POS Commands

The output command for the specified pulse and the status transmission command are provided. For details, see the ESC/POS Command Reference.

For Windows Printer Drivers (APD)

You can set so that the drawer opens at the start/end of printing or start/end of a page. For details, see the manual for drivers.

For details on control, see the manual for Status API of the driver.

OPOS (OCX Driver)

Register a cash drawer using the SetupPOS Utility, and control using the OpenDrawer method or the DirectIO function.

For details, see the “EPSON OPOS ADK MANUAL APPLICATION DEVELOPMENT GUIDE Cash Drawer” and the “UnifiedPOS Specification”.

OPOS for .NET

Register a cash drawer using the SetupPOS Utility, and control using the OpenDrawer method or the DirectIO function.

For details, see the “EPSON OPOS ADK for .NET MANUAL Application Development Guide Cash Drawer (EPSON Standard)” and the “UnifiedPOS Specification”.

Epson ePOS SDK

The output command for the drawer kick pulse and the status transmission command are provided in the SDK library. For details, see the user's manuals provided with the SDK.

NOTE

- Which drawer kick connector, pin 2 or pin 5, is used for operation depends on the connected cash drawer.
- You can acquire documents regarding the UnifiedPOS from the following link.
<https://www.omg.org/retail/unified-pos.htm>

Software

The following software is provided for application development.

Development Kits

Software	Description
EPSON OPOS ADK	This OCX driver can control POS peripherals using OLE technology ^{*1} . Because controlling POS peripherals with original commands is not required on the application side, efficient system development is possible.
EPSON OPOS ADK for .NET	The OPOS ADK for .NET is a POS industry standard printer driver compatible with Microsoft POS for .NET. It allows you to develop applications that are compatible with the UPOS (Unified POS) specification. When developing applications, use a separate development environment such as Microsoft Visual Studio .NET.
EPSON JavaPOS ADK (Windows/Linux)	JavaPOS is the standard specification which defines an architecture and device interface (API) to access various POS devices from a Java based system. Using JavaPOS standard API allows control with Java based applications of functions inherent to each device. A flexible design with Java language and JavaPOS enables many different types of computer systems, such as stand alone or network configuration, to use a same application. You can use JavaPOS to build applications and drivers independently of platforms. This allows flexible configurations using thin clients to meet the system requirements.
Epson ePOS SDK for JavaScript	This is a developer kit to control printers via a Web application. This includes libraries, manuals, and sample programs.

*1: OLE technology developed by Microsoft divides software into part blocks. The OPOS driver is presupposed to be used with a development environment, such as Visual Basic, unlike ordinary Windows printer drivers. It is not a driver to be used for printing from commercial applications.

You can acquire documents regarding the UnifiedPOS from the following link.
<https://www.omg.org/retail/unified-pos.htm>

Drivers

Software	Description	Operating environment
EPSON Advanced Printer Driver (APD)	In addition to ordinary Windows printer driver functions, this driver has controls specific to POS. The Status API (Epson original DLL) that monitors printer status and sends ESC/POS commands is also attached to this driver.	Windows
EPSON TM Virtual Port Driver	This is a serial/parallel-USB/LAN conversion driver to make an Epson TM/BA/EU printer connected via USB or LAN accessible from a POS application through a virtual serial or parallel port. It allows you to directly control devices connected via USB or LAN with ESC/POS commands without making changes in the POS application that controls devices connected via a serial or parallel interface.	Windows

Utilities

Software	Description	Operating environment
TMFlogo Logo Setup Utility	Used to register logos (for example, shop logos) to the NV memory of the printer.	Windows
MSWUTL Memory Switch Setting Utility	Used to change the settings for the memory switches and customized values of the printer.	Windows
EpsonNet Config	A network setting tool for Epson network products.	Windows Mac
Epson Deployment Tool	Use to make network and printer settings simultaneously. Allows you to make settings efficiently at the time of introducing TM printers for the first time, or when configuring multiple TM printers at the same time.	Windows
Epson Monitoring Tool	Use to check a list of status for the Epson printers connected to the network. You can also update certificates for multiple printers used for WPA2-Enterprise in a batch.	Windows
EPSON TMUSB Identifier Utility	A tool used to change the USB identification code (USB Serial No.). Using this tool makes replacement due to a failure easier.	Windows

Download

You can obtain software and manuals from one of the following URLs.

For customers in North America, go to the following web site:

www.epson.com/support/

For customers in other countries, go to the following web site:

www.epson-biz.com/?service=pos



Handling

This chapter describes basic handling of the printer.

Installing and Replacing Roll Paper



CAUTION

- Do not open the roll paper cover while printing or autocutting. The printer may be damaged.
- Do not touch the manual cutter with your hands when installing or replacing the roll paper. Doing so may injure your hand or finger.

CAUTION

- Use roll paper that meets the printer specification. For details about paper specification, see "[Paper Specifications](#)" on page 83.
- Do not use a roll paper whose end is pasted to the paper core.

- 1 Press the cover open lever to open the roll paper cover.

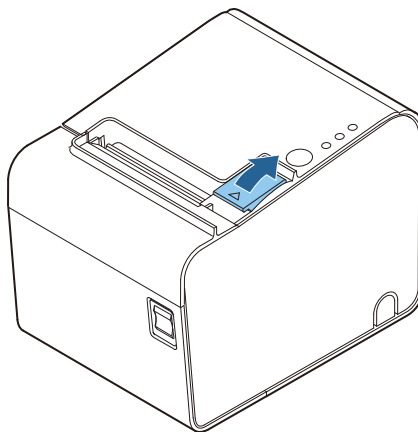

- 2 Remove the used roll paper core, if any.

3 Install the roll paper in the correct direction.

Horizontal installation

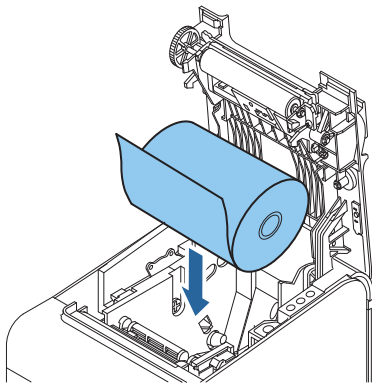

Vertical/wall-hanging installation

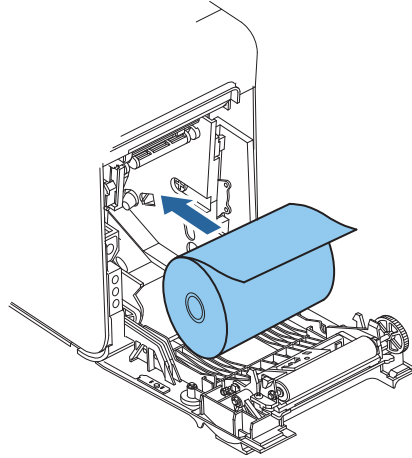

4 Pull out some roll paper along the guide, and close the roll paper cover.
Close the roll paper cover firmly by pressing the center of the cover.

Horizontal installation

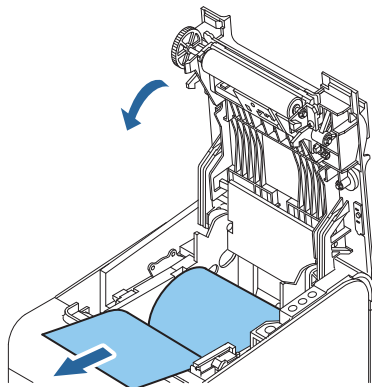

Vertical/wall-hanging installation

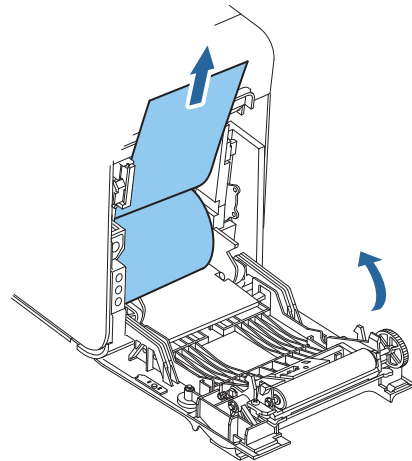

5 Cut the roll paper with the manual cutter.
When the printer power is on, the roll paper is automatically cut.

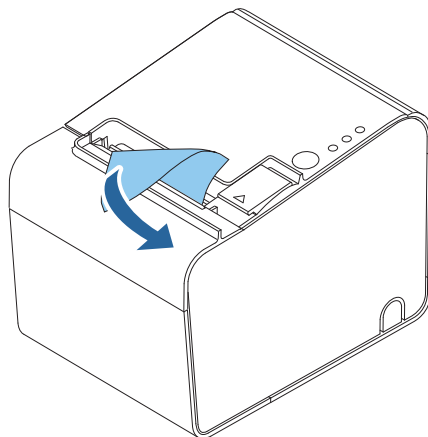

Removing Jammed Paper

**CAUTION**

Do not touch the thermal head. (See ["Cleaning the Printer" on page 68.](#))
After printing, the thermal head and its surroundings can be very hot.

- 1 Turn off the printer.
- 2 Press the cover open lever to open the roll paper cover.

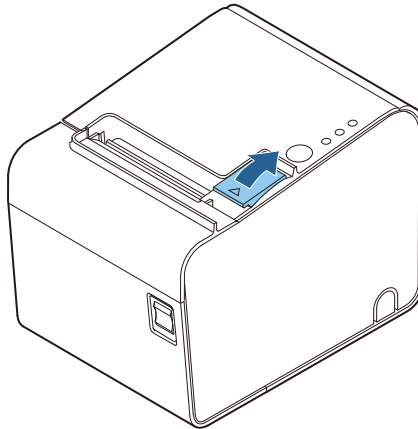

- 3 Remove the jammed paper.

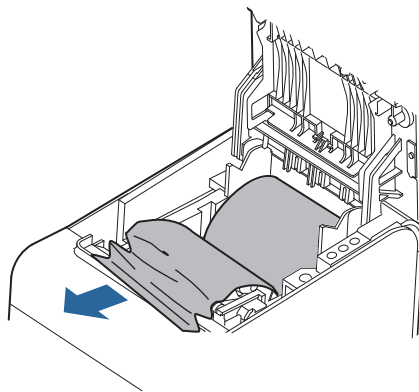

- 4 Reinstall the roll paper and close the roll paper cover.

NOTE

If the printer is used for a long time, the platen roller may become worn out, allowing the liner-free label paper to stick to the platen roller easily. If you leave the liner-free label paper in the printer for a long time, the liner-free label paper may stick to the platen roller, which may cause paper jams.

If a paper jam occurs, clean the inside of the printer. (["Cleaning the Inside of the Printer" on page 68](#))

If paper jams occur frequently even after cleaning, replace the platen roller. Contact qualified service personnel.

It may be possible to prevent paper jams in advance by reinstalling the roll paper. (["Installing and Replacing Roll Paper" on page 63](#))

If you leave the 68* model printer turned on for a long time (approx. 12 hours) without printing, periodic paper feed is operated automatically in order to prevent the liner-free label paper from sticking to the platen roller. During the next print after the paper feed operation, the top margin is increased even when back feed is enabled. When back feed is disabled, printing errors may occur.

When the Roll Paper Cover Cannot be Opened

If a foreign substance has entered the autocutter or the roll paper jams, the autocutter blade cannot return to the correct position and it locks in place. In this situation, the roll paper cover does not open even if you pull the cover open lever.

Follow the procedures below to return the autocutter blade to its normal position.

- 1 Turn off the printer.
- 2 Insert a screwdriver into the indents on both sides of the printer, and lift the cutter cover to remove the cover.

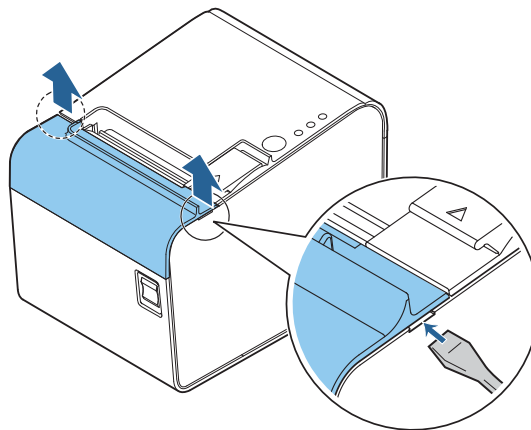

- 3 Turn the knob until you see a triangle in the opening. This returns the cutter blade to the normal position.

When the autocutter blade returns to the normal position, you can open the roll paper cover.

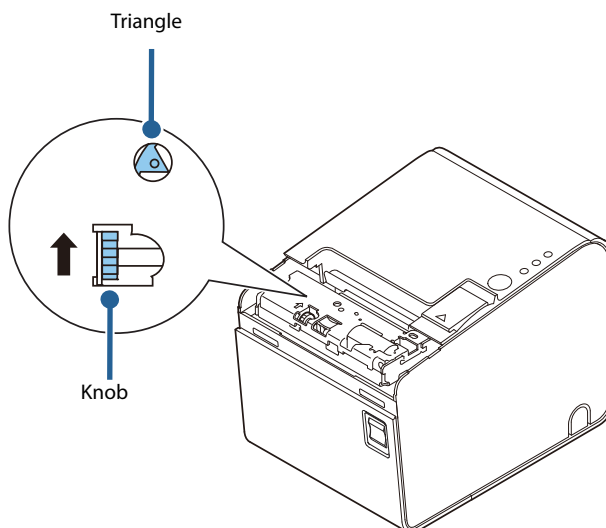

- 4 Close the cutter cover.
- 5 Open the roll paper cover and remove foreign matter and jammed paper.

Cleaning the Printer

Cleaning the Printer Case

Be sure to turn off the printer, and wipe the dirt off the printer case with a dry cloth or a damp cloth. Be sure to unplug the AC cable while cleaning.



CAUTION

Never clean the product with alcohol, benzene, thinner, trichloroethylene, or ketone-based solvents.
Doing so may damage or break the parts made of plastic and rubber.

Cleaning the Inside of the Printer

Epson recommends cleaning the inside of the printer periodically (generally every 6 months) to maintain print quality. Paper dust or glue from the label paper accumulated in the printer may cause an irregular paper feed, improper cutting, or paper jams.

Turn on the printer power only after the cleaned area has completely dried.

Thermal head and its surroundings

Turn off the printer and open the roll paper cover. Clean the thermal elements of the thermal head and its surroundings with a cotton swab moistened with an alcohol solvent (ethanol or IPA).



CAUTION

- After printing, the thermal head can be very hot. Let it cool before you clean it.
- Do not damage the thermal head by touching it with your fingers or any hard object.

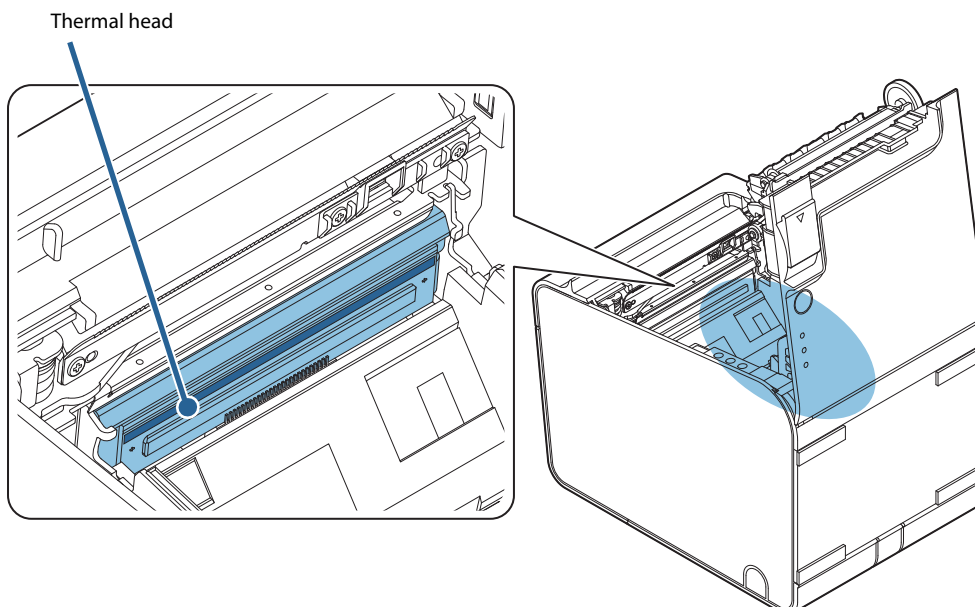

Cleaning paper path/autocutter/platen roller

Turn off the printer and open the roll paper cover. Clean the paper dust and adhesive substance accumulated in the printer with a cotton swab or nonwoven fabric moistened with an alcohol solvent (ethanol or IPA).

**WARNING**

Do not touch the edge of the autocutter blade directly with your finger. Doing so may injure your finger.

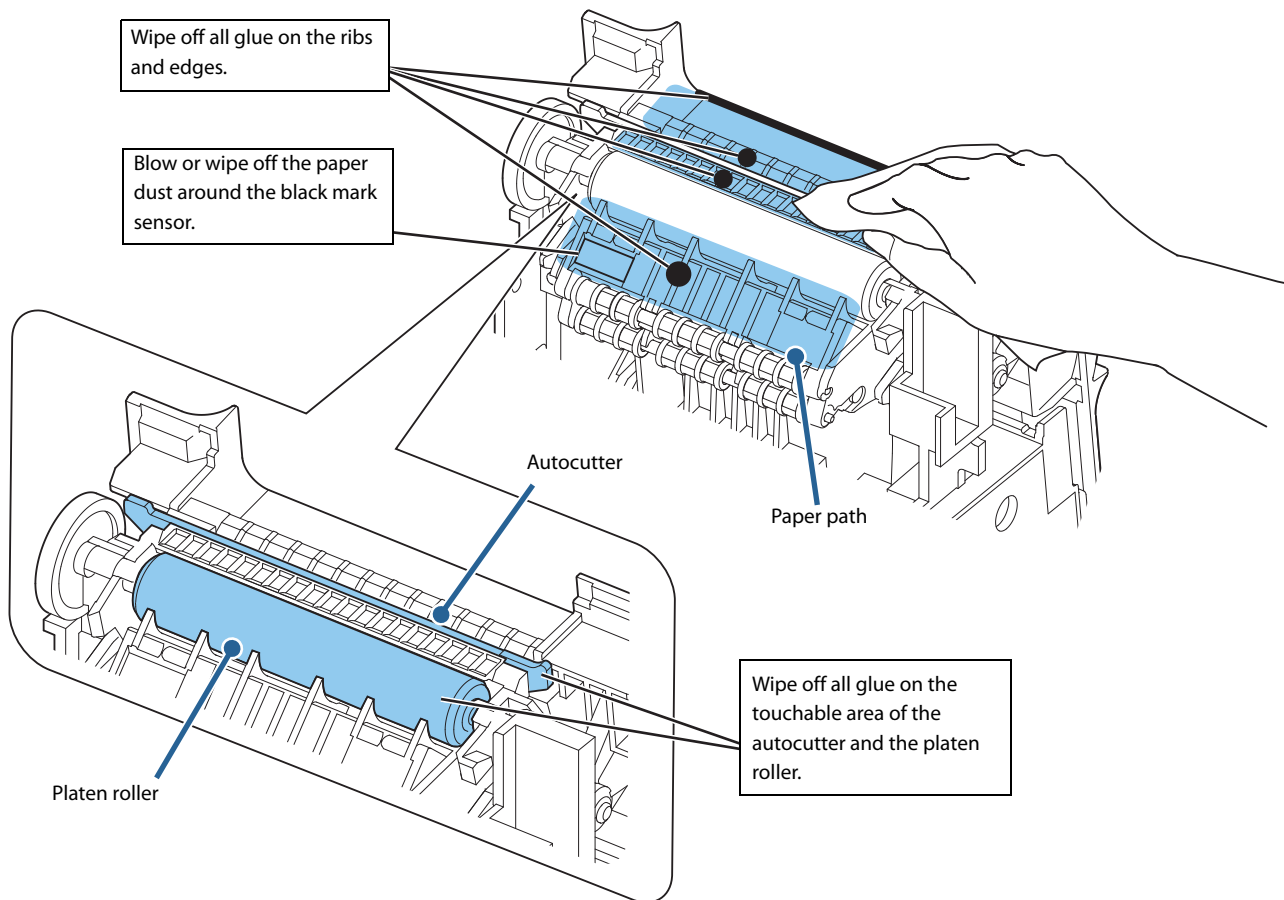

Preparing for Transport

Follow the procedures below to transport the printer.

- 1** Turn off the printer by operating the power switch.
- 2** Ensure that the  LED has turned off.
- 3** Disconnect the power supply connector.
- 4** Remove the roll paper.
- 5** Pack the printer upright.

Appendix

Product Specifications

Printing method	Thermal line printing	
Cutting type	Partial cut (cutting with one point in left edge left uncut)	
Roll paper width	65* model Width 40 mm ^{*1} Width 80 mm	
	Other than the 65* model Width 40 mm ^{*1} Width 58 mm Width 80 mm	
Interface	USB: USB 2.0 Full-speed (12 Mbps) Ethernet: 10BASE-T/100BASE-TX Serial: RS-232 Wireless LAN: Connecting an optional Wireless LAN unit to the USB connector.	
Buffers	Receive buffer	4 KB/45 bytes (selectable using memory switch 1-2)
	Downloaded buffer	Downloaded bit image: Approximately 12 KB User-defined characters: Approximately 11 KB
	Macro buffer	2 KB
	NV (Non-volatile) graphics data area:	0 to 384 KB
	User NV memory	1 to 192 KB
	Page mode area	106 KB
Barcode/two-dimensional symbol printing	UPC-A, UPC-E, JAN 8 (EAN 8), JAN 13 (EAN 13), CODE 39, ITF, CODABAR (NW-7), CODE 93, CODE 128, PDF417, MaxiCode, QRCode	
Power supply	Power supplied by the PS-180 AC adapter	

Life ^{*2 *3}	Printer mechanism	Thermal paper: 20,000,000 lines Liner-free label paper: 10,000,000 lines
	Thermal head	Thermal paper: 150 million pulses, 150 km Liner-free label paper: 75 million pulses, 75 km
	Autocutter	Thermal paper: 2,000,000 cuts Liner-free label paper: 1,000,000 cuts (at the glued area cut rate = 50%)
	Platen roller	Liner-free label paper: <ul style="list-style-type: none"> • 80 mm width paper: 16 km • 58 mm width paper: 16 km • 40 mm width paper: 56 km
MTBF ^{*4}		360,000 hours
MCBF ^{*5}		Thermal paper: 70,000,000 lines Liner-free label paper: 35,000,000 lines
Temperature/humidity		Thermal paper <ul style="list-style-type: none"> • Operating: 5°C to 45°C {41°F to 113°F}, 10% to 90% RH • Storage: -10°C to 50°C {14°F to 122°F}, 10% to 90% RH Liner-free label paper <ul style="list-style-type: none"> • Operating: 5°C to 35°C {41°F to 95°F}, 20% to 80% RH • Storage: -10°C to 50°C {14°F to 122°F}, 10% to 90% RH
External dimensions (H × W × D)		148 × 140 × 203 mm {5.83 × 5.51 × 7.99"}
Mass		Approximately 1.9 kg {4.19 lb} (roll paper excluded)

*1: Liner-free label paper only

*2: Changes depending on the paper type and model to be used.

*3: Indicates the point at which the wear-out failure period starts.

*4: Indicates the mean time between failures during the random failure period.

*5: Indicates the overall mean time between failures, including wear-out and random failures, before the life is reached.

Printing Specifications

	40 mm width paper	58 mm width paper	80 mm width paper
Printing method	Thermal line printing		
Dot density	203 × 203 dpi		
Printing direction	Unidirectional with friction feed		
Maximum printable area	35.0 mm {1.38"}, 280 dot positions	52.5 mm {2.07"}, 420 dot positions	72.0 mm {2.83"}, 576 dot positions
Characters per line*1	Font A Auto scaling • Disabled: 23 • Enabled: 40	Auto scaling • Disabled: 30 • Enabled: 42	Compatible mode • TM-T88 series (1): 42 • TM-T88 series (2): 44 • TM-L90: 48
	Font B Auto scaling • Disabled: 31 • Enabled: 40	Auto scaling • Disabled: 40 • Enabled: 60	Compatible mode • TM-T88 series (1): 55 • TM-T88 series (2): 57 • TM-L90: 64
Maximum print speed (Standard printing)*2	Printing on thermal paper: 170 mm/s *3 Printing on liner-free label paper: 90 mm/s		
Line spacing	3.75 mm {0.15"} 40 mm width paper with auto scaling enabled: 1.75 mm {0.07"} * Default setting, programmable by command		

*1: Auto scaling and compatible mode are selectable using memory switch 6 ("[Memory Switch 6](#)" on page 40)

For the 67*/68* (multilingual) models, see auto scaling disabled/TM-L90 compatible mode.

*2: At 24 V, 25°C, with standard print density

*3: Maximum print speed changes in the following case:

- Vertical barcode/two-dimensional symbol printing: 90 mm/s

dpi: dots per inch

CAUTION

- To change the paper width, the 40 mm roll paper guide is required. ("[Changing the Paper Width](#)" on page 25)
- Because some parts of the print head and the autocutter blade may contact the platen and become worn out, you cannot change a smaller paper width to a larger one once you start using the product.

NOTE

- Printing speed may be slower, depending on items such as the print data, head temperature, and energization parting.
- As vertical barcodes and two-dimensional symbols are printed after the specified speed is reached, paper may be fed unprinted for a maximum of 10 dot lines.

Character Specifications

	40 mm width paper	58 mm width paper	80 mm width paper	
Character type	Alphanumeric characters: 95 Extended graphics: 128 × 11 pages (including user-defined page) International character set: 37			
Character structure (Horizontal dot × Vertical dot)*	Font A	Auto scaling • Disabled: 12x24 • Enabled: 7x17	Auto scaling • Disabled: 13x24 • Enabled: 10x24	Compatible mode • TM-T88 series: 13 × 24 • TM-L90: 12 × 24
	Font B	Auto scaling • Disabled: 9x17 • Enabled: 7x17	Auto scaling • Disabled: 10x17 • Enabled: 7x17	Compatible mode • TM-T88 series: 10x17 • TM-L90: 9 × 17
Character size* Standard/double-height/double-width/double-height/double-width/double-height/double-width/double-height (horizontal × vertical)	Font A	Auto scaling • Disabled: 12 × 24 mm {0.47 × 0.94"}/ 12 × 48 mm {0.47 × 1.89"}/ 24 × 24 mm {0.94 × 0.94"}/ 24 × 48 mm {0.94 × 1.89"} • Enabled: 7 × 17 mm {0.28 × 0.67"}/ 7 × 34 mm {0.28 × 1.33"}/ 14 × 17 mm {0.55 × 0.67"}/ 12 × 24 mm {0.47 × 0.94"} • Enabled:	Auto scaling • Disabled: 13 × 24 mm {0.51 × 0.94"}/ 13 × 48 mm {0.94 × 1.89"}/ 26 × 24 mm {1.02 × 0.94"}/ 26 × 48 mm {1.02 × 1.89"} • Enabled: 10 × 24 mm {0.39 × 0.94"}/ 10 × 48 mm {0.39 × 1.89"}/ 20 × 24 mm {0.79 × 0.94"}/ 20 × 48 mm {0.79 × 1.89"} • Enabled:	Compatible mode • TM-T88 series: 13 × 24 mm {0.51 × 0.94"}/ 13 × 48 mm {0.94 × 1.89"}/ 26 × 24 mm {0.94 × 1.89"}/ 26 × 48 mm {1.02 × 1.89"} • TM-L90: 12 × 24 mm {0.47 × 0.94"}/ 12 × 48 mm {0.47 × 1.89"}/ 24 × 24 mm {0.94 × 0.94"}/ 24 × 48 mm {0.94 × 1.89"} • TM-L90:
	Font B	Auto scaling • Disabled: 9 × 17 mm {0.35 × 0.67"}/ 9 × 34 mm {0.35 × 1.34"}/ 18 × 17 mm {0.71 × 0.67"}/ 18 × 34 mm {0.71 × 1.34"} • Enabled: 7 × 17 mm {0.28 × 0.67"}/ 7 × 34 mm {0.28 × 1.34"}/ 14 × 17 mm {0.55 × 0.67"}/ 12 × 34 mm {0.47 × 1.34"} • Enabled:	Auto scaling • Disabled: 10 × 17 mm {0.39 × 0.67"}/ 10 × 34 mm {0.39 × 1.34"}/ 20 × 17 mm {0.79 × 0.67"}/ 20 × 34 mm {0.79 × 1.34"} • Enabled: 7 × 17 mm {0.28 × 0.67"}/ 7 × 34 mm {0.28 × 1.34"}/ 14 × 17 mm {0.55 × 0.67"}/ 14 × 34 mm {0.55 × 1.34"} • Enabled:	Compatible mode • TM-T88 series: 10 × 17 mm {0.39 × 0.67"}/ 10 × 34 mm {0.39 × 1.34"}/ 20 × 17 mm {0.79 × 0.67"}/ 20 × 34 mm {0.79 × 1.34"} • TM-L90: 9 × 17 mm {0.35 × 0.67"}/ 9 × 34 mm {0.35 × 1.34"}/ 18 × 17 mm {0.71 × 0.67"}/ 18 × 34 mm {0.71 × 1.34"} • TM-L90:

*: Auto scaling and compatible mode are selectable using memory switch 6 ("[Memory Switch 6](#)" on page 40)

For the 67*/68* (multilingual) models, see auto scaling disabled, TM-L90 compatible mode.

Note:

1. The actual print character may be smaller than the size shown in the table above, because the above sizes include spaces in the font.
2. Characters can be scaled up to 64 times as large as the standard sizes shown above.
3. Character size not including the horizontal spacing in the standard scale is as follows:

<Auto scaling disabled>

Font A (standard): $1.25 (W) \times 3.00 (H) \text{ mm } \{0.05 (W) \times 0.12 (H)\}$

Font A (double-width/double-height): $2.50 (W) \times 6.00 (H) \text{ mm } \{0.10 (W) \times 0.24 (H)\}$

Font B (standard): $0.88 (W) \times 2.13 (H) \text{ mm } \{0.03 (W) \times 0.08 (H)\}$

Font B (double-width/double-height): $1.75 (W) \times 4.25 (H) \text{ mm } \{0.07 (W) \times 0.17 (H)\}$

<Auto scaling enabled>

40 mm width paper

Font A (standard): $0.88 (W) \times 2.13 (H) \text{ mm } \{0.03 (W) \times 0.08 (H)\}$

Font A (double-width/double-height): $1.25 (W) \times 3.00 (H) \text{ mm } \{0.05 (W) \times 0.12 (H)\}$

Font B (standard): $0.88 (W) \times 2.13 (H) \text{ mm } \{0.03 (W) \times 0.08 (H)\}$

Font B (double-width/double-height): $1.75 (W) \times 4.25 (H) \text{ mm } \{0.07 (W) \times 0.17 (H)\}$

58 mm width paper

Font A (standard): $1.125 (W) \times 3.00 (H) \text{ mm } \{0.04 (W) \times 0.12 (H)\}$

Font A (double-width/double-height): $2.25 (W) \times 6.00 (H) \text{ mm } \{0.09 (W) \times 0.24 (H)\}$

Font B (standard): $0.88 (W) \times 2.13 (H) \text{ mm } \{0.03 (W) \times 0.08 (H)\}$

Font B (double-width/double-height): $1.75 (W) \times 4.25 (H) \text{ mm } \{0.07 (W) \times 0.17 (H)\}$

Details of Characters Per Line and Character Specifications with Auto Scaling Enabled

Auto scaling automatically reduces print data that is outside the print area for 40/58 mm width paper to the print area for 40 mm width paper. Details of characters per line and character specifications with auto scaling enabled are as shown below.

NOTE

- Enabled only when 40/58 mm width paper is used.
- Enabled/disabled by memory switch 6-8. ("Memory Switch 6" on page 40)

MSW 6-8: OFF (40 mm/80 mm)

When using 40 mm width roll paper, received print data is automatically compressed in the vertical and horizontal directions.

Font A

			Receipt print data	Print data to be scaled down by auto scaling	
Compatible mode	MSW 6-4	MSW 6-5	Specified character size	Print area: 72.0 mm {2.83"} Printed characters: 576 dots	Print area: 35.0 mm {1.38"} Printed characters: 280 dots
			TM-T88 series compatible mode (1)	ON	ON
Double width/ Double height	Characters per line: 21 ^{*1}	Character font: 12 × 24 Characters per line: 23 ^{*2}			
(n × width) × (m × height) (double width/ double height excluded)	Characters per line: 552 dots ÷ (13 × n) The remainder is rounded down. ^{*1}	When n and m are both even values Character font: (12 × (n ÷ 2)) × (24 × (m ÷ 2)) Characters per line: 280 dots ÷ (12 × (n ÷ 2)) The remainder is rounded down. ^{*2}			
				When neither n or m are even values Character font: (7 × n) × (17 × m) Characters per line: 280 dots ÷ (7 × n) The remainder is rounded down. ^{*2}	

				Receipt print data	Print data to be scaled down by auto scaling
Compatible mode	MSW 6-4	MSW 6-5	Specified character size	Print area: 72.0 mm {2.83"}	Print area: 35.0 mm {1.38"}
				Printed characters: 576 dots	Printed characters: 280 dots
TM-T88 series compatible mode (2)	ON	OFF	Actual size	Characters per line: 44	Character font: 7 × 17 Characters per line: 40
			Double width/ Double height	Characters per line: 22	Character font: 12 × 24 Characters per line: 23 *2
			(n × width) × (m × height) (double width/ double height excluded)	Characters per line: 576 dots ÷ (13 × n) The remainder is rounded down.	When n and m are both even values Character font: (12 × (n ÷ 2)) × (24 × (m ÷ 2)) Characters per line: 280 dots ÷ (12 × (n ÷ 2)) The remainder is rounded down. *2
					When neither n or m are even values Character font: (7 × n) × (17 × m) Characters per line: 280 dots ÷ (7 × n) The remainder is rounded down. *2

			Receipt print data	Print data to be scaled down by auto scaling	
Compatible mode	MSW 6-4	MSW 6-5	Specified character size	Print area: 72.0 mm {2.83"}	Print area: 35.0 mm {1.38"}
				Printed characters: 576 dots	Printed characters: 280 dots
TM-L90 compatible mode	OFF	OFF	Actual size	Characters per line: 48	Character font: 7 × 17 Characters per line: 40
			Double width/ Double height (double width/ double height excluded)	Characters per line: 24	Character font: 12 × 24 Characters per line: 23 ^{*2}
			(n × width) × (m × height) (double width/ double height excluded)	Characters per line: 576 dots ÷ (12 × n) The remainder is rounded down.	When n and m are both even values Character font: (12 × (n ÷ 2)) × (24 × (m ÷ 2)) Characters per line: 280 dots ÷ (12 × (n ÷ 2)) The remainder is rounded down. ^{*2}
					When neither n or m are even values Character font: (7 × n) × (17 × m) Characters per line: 280 dots ÷ (7 × n) The remainder is rounded down. ^{*2}

*1: The print area is 68.25 mm {2.69"} and 552 dots.

*2: Only when Font A is specified and double width/double height is set, the font during auto scaling is 12 x 24.

Font B

				Receipt print data	Print data to be scaled down by auto scaling
Compatible mode	MSW 6-4	MSW 6-5	Specified character size	Print area: 72.0 mm {2.83"}	Print area: 35.0 mm {1.38"}
				Printed characters: 576 dots	Printed characters: 280 dots
TM-T88 series compatible mode (1)	ON	ON	Actual size	Characters per line: 55 ^{*1}	Character font: 7 × 17 Characters per line: 40
			Double width/ Double height	Characters per line: 27 ^{*1}	Character font: 14 × 34 Characters per line: 20
			(n × width) × (m × height) (double width/ double height excluded)	Characters per line: 552 dots ÷ (10 × n) The remainder is rounded down. ^{*1}	Character font: (7 × n) × (17 × m) Characters per line: 280 dots ÷ (7 × n) The remainder is rounded down.
TM-T88 series compatible mode (2)	ON	OFF	Actual size	Characters per line: 57	Character font: 7 × 17 Characters per line: 40
			Double width/ Double height	Characters per line: 28	Character font: 12 × 34 Characters per line: 20
			(n × width) × (m × height) (double width/ double height excluded)	Characters per line: 576 dots ÷ (10 × n) The remainder is rounded down.	Character font: (7 × n) × (17 × m) Characters per line: 280 dots ÷ (7 × n) The remainder is rounded down.
TM-L90 compatible mode	OFF	OFF	Actual size	Characters per line: 64	Character font: 7 × 17 Characters per line: 40
			Double width/ Double height	Characters per line: 32	Character font: 14 × 34 Characters per line: 20
			(n × width) × (m × height) (double width/ double height excluded)	Characters per line: 576 dots ÷ (9 × n) The remainder is rounded down.	Character font: (7 × n) × (17 × m) Characters per line: 280 dots ÷ (7 × n) The remainder is rounded down.

*1: The print area is 68.25 mm {2.69"} and 552 dots.

MSW 6-8: ON (58 mm/80 mm)

When using 58 mm width roll paper, received print data is automatically compressed in the vertical and horizontal directions.

Font A

			Receipt print data		Print data to be scaled down by auto scaling	
Compatible mode	MSW 6-4	MSW 6-5	Specified character size	Print area: 72.0 mm {2.83"} Printed characters: 576 dots	Print area: 52.5 mm {2.07"} Printed characters: 420 dots	
	TM-T88 series compatible mode (1)	ON		ON	Actual size	Characters per line: 42 ^{*1}
			Double width/ Double height	Characters per line: 21 ^{*1}	Character font: 20 × 48 Characters per line: 21	
			(n × width) × (m × height) (double width/ double height excluded)	Characters per line: 552 dots ÷ (10 × n) The remainder is rounded down. ^{*1}	Character font: (10 × n) × (24 × m) Characters per line: 420 dots ÷ (10 × n) The remainder is rounded down.	
TM-T88 series compatible mode (2)	ON	OFF	Actual size	Characters per line: 44	Character font: 10 × 24 Characters per line: 42	
			Double width/ Double height	Characters per line: 22	Character font: 20 × 48 Characters per line: 21	
			(n × width) × (m × height) (double width/ double height excluded)	Characters per line: 576 dots ÷ (10 × n) The remainder is rounded down.	Character font: (10 × n) × (24 × m) Characters per line: 420 dots ÷ (10 × n) The remainder is rounded down.	
TM-L90 compatible mode	OFF	OFF	Actual size	Characters per line: 48	Character font: 10 × 24 Characters per line: 42	
			Double width/ Double height	Characters per line: 24	Character font: 20 × 48 Characters per line: 21	
			(n × width) × (m × height) (double width/ double height excluded)	Characters per line: 576 dots ÷ (10×n) The remainder is rounded down.	Character font: (10 × n) × (24 × m) Characters per line: 420 dots ÷ (10 × n) The remainder is rounded down.	

*1: The print area is 68.25 mm {2.69"} and 552 dots.

Font B

				Receipt print data	Print data to be scaled down by auto scaling
Compatible mode	MSW 6-4	MSW 6-5	Specified character size	Print area: 72.0 mm {2.83"} Printed characters: 576 dots	Print area: 52.5 mm {2.07"} Printed characters: 420 dots
	TM-T88 series compatible mode (1)	ON		ON	Actual size
Double width/ Double height			Characters per line: 27 ^{*1}		Character font: 14 × 34 Characters per line: 30
(n × width) × (m × height) (double width/ double height excluded)			Characters per line: 552 dots ÷ (7 × n) The remainder is rounded down. ^{*1}		Character font: (7 × n) × (17 × m) Characters per line: 420 dots ÷ (7 × n) The remainder is rounded down.
TM-T88 series compatible mode (2)	ON	OFF	Actual size	Characters per line: 57	Character font: 7 × 17 Characters per line: 60
			Double width/ Double height	Characters per line: 28	Character font: 14 × 34 Characters per line: 20
			(n × width) × (m × height) (double width/ double height excluded)	Characters per line: 576 dots ÷ (7 × n) The remainder is rounded down.	Character font: (7 × n) × (17 × m) Characters per line: 420 dots ÷ (7 × n) The remainder is rounded down.
TM-L90 compatible mode	OFF	OFF	Actual size	Characters per line: 64	Character font: 7 × 17 Characters per line: 60
			Double width/ Double height	Characters per line: 32	Character font: 14 × 34 Characters per line: 20
			(n × width) × (m × height) (double width/ double height excluded)	Characters per line: 576 dots ÷ (7×n) The remainder is rounded down.	Character font: (7 × n) × (17 × m) Characters per line: 420 dots ÷ (7 × n) The remainder is rounded down.

*1: The print area is 68.25 mm {2.69"} and 552 dots.

When receiving 512-dot print data for TM-T88 series models

If 512-dot print data for TM-T88 series models is received when using 58 mm width roll paper, it is automatically compressed in the vertical and horizontal directions.

Font A

			Receipt print data	Print data to be scaled down by auto scaling	
Compatible mode	MSW 6-4	MSW 6-5	Specified character size	Print area: 72.0 mm {2.83"}	Print area: 52.5 mm {2.07"}
				Printed characters: 512 dots	Printed characters: 420 dots
Any mode	ON/ OFF	ON/ OFF	Actual size	Characters per line: 42	Character font: 10 × 24 Characters per line: 42
			(n × width) × (m × height) (double width/ double height excluded)	Characters per line: 512 dots ÷ (10 × n) The remainder is rounded down.	Character font: (10 × n) × (24 × m) Characters per line: 420 dots ÷ (10 × n) The remainder is rounded down.

Font B

			Receipt print data	Print data to be scaled down by auto scaling	
Compatible mode	MSW 6-4	MSW 6-5	Specified character size	Print area: 72.0 mm {2.83"}	Print area: 52.5 mm {2.07"}
				Printed characters: 512 dots	Printed characters: 420 dots
Any mode	ON/ OFF	ON/ OFF	Actual size	Characters per line: 60	Character font: 7 × 17 Characters per line: 60
			(n × width) × (m × height) (double width/ double height excluded)	Characters per line: 512 dots ÷ (7 × n) The remainder is rounded down.	Character font: (7 × n) × (17 × m) Characters per line: 420 dots ÷ (7 × n) The remainder is rounded down.

Paper Specifications

		40 mm width paper ^{*1}	58 mm width paper	80 mm width paper
Paper type^{*2}		<ul style="list-style-type: none"> • Thermal paper • Liner-free label paper 		
Form		Roll paper		
Size	Paper width	Width 39.5 ± 0.5 mm {1.56 ± 0.02"}}	Width 57.5 ± 0.5 mm {2.24 ± 0.02"}}	Width 79.5 ± 0.5 mm {3.13 ± 0.02"}}
	Roll paper diameter	Max. diameter: 102 mm {4.02"}}		
	Roll paper spool diameter	<ul style="list-style-type: none"> • Thermal paper: 18 mm {0.71"} or more • Liner-free label paper: 31.8 mm {1.25"}} 		
	Roll width when taken up	<ul style="list-style-type: none"> • Liner-free label paper: 39.5 + 1.044/-0.5 mm {1.56 + 0.04/-0.02"}} 	<ul style="list-style-type: none"> • Thermal paper: 57.5 + 1/-0.5 mm {2.26 + 0.04/-0.02"}} • Liner-free label paper: 57.5 + 1.2/-0.5 mm {2.26 + 0.05/-0.02"}} 	<ul style="list-style-type: none"> • Thermal paper: 79.5 + 1/-0.5 mm {3.13 + 0.04/-0.02"}} • Liner-free label paper: 79.5 + 1.0/-0.5 mm {3.13 + 0.04/-0.02"}}
Specified roll paper type no.: (liner-free label paper)		<ul style="list-style-type: none"> • 9023-1275 Lane Coated: 6 rolls • 9023-1257 Lane Coated: 12 rolls (Iconex(USA)) 	<ul style="list-style-type: none"> • 9023-1823 Lane Coated: 12 rolls • 9023-1397 Lane Coated: 30 rolls (Iconex(USA)) 	<ul style="list-style-type: none"> • 9023-1274 Lane Coated: 6 rolls • 9023-1253 Lane Coated: 12 rolls (Iconex(USA))
Specified original paper type no.: (Thermal paper)		<ul style="list-style-type: none"> • TF50KS-EY NIPPON Paper Industries Co., Ltd.)...Specified paper • P35524 (Kanzaki Specialty Papers (USA)) • P31523 (Kanzaki Specialty Papers (USA)) • P30523 (Kanzaki Specialty Papers (USA)) • F5041(55) (Mitsubishi HiTec Paper Flensburg gmbH (Germany)) • KF50 (KANZAN Spezialpapiere gmbH) • KT55FA (Papierfabrik August Koehler SE (Germany)) • KT48FA (Papierfabrik August Koehler SE (Germany)) • AF50KS-E (Jujo Thermal Ltd (Finland)) 		

*1: Liner-free label paper only

*2: The paper type is automatically detected by whether black marks exist or not.

CAUTION

- Paper must not be pasted to the roll paper spool.
- For the best print quality and reliability for each paper type, it is recommended to set the print density ("[Selection of printing density](#)" on page 43).

Black mark printing specifications for liner-free label paper

When using liner-free label paper, the paper must meet the following conditions:

- Black marks are printed on the back side (non-printing side)
- The combination of reflection rate of each area satisfies the table below.

Note: Reflection rates are measured by the Macbeth PCM-II (Filter D). The back of the paper is measured.

Reflection rate of black mark area (1)	17% or less	16% or less	15% or less	14% or less	13% or less
Reflection rate of area outside black mark (2)	90% or more	85% or more	80% or more	75% or more	70% or more

80/58 mm width paper

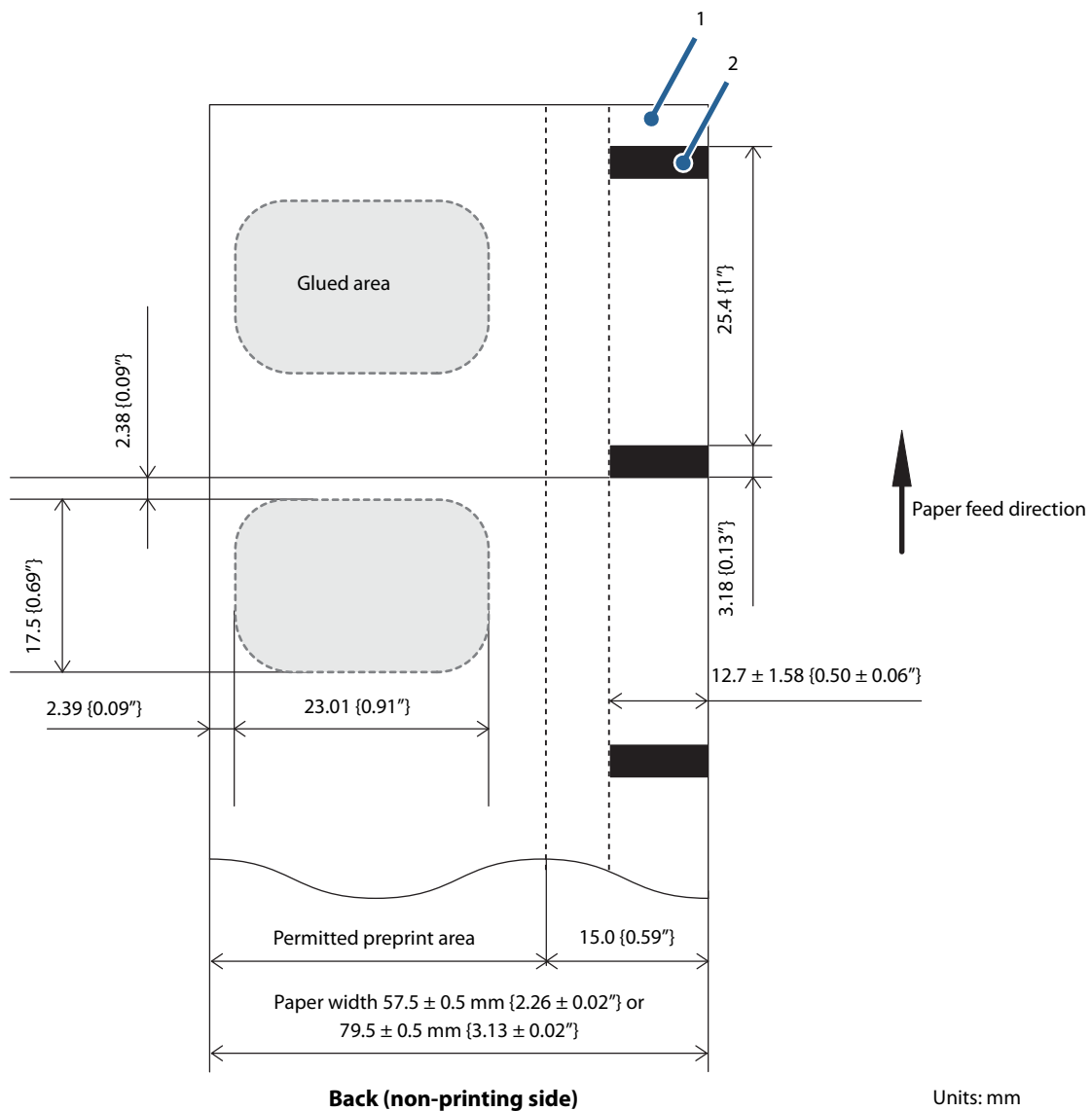

40 mm width paper

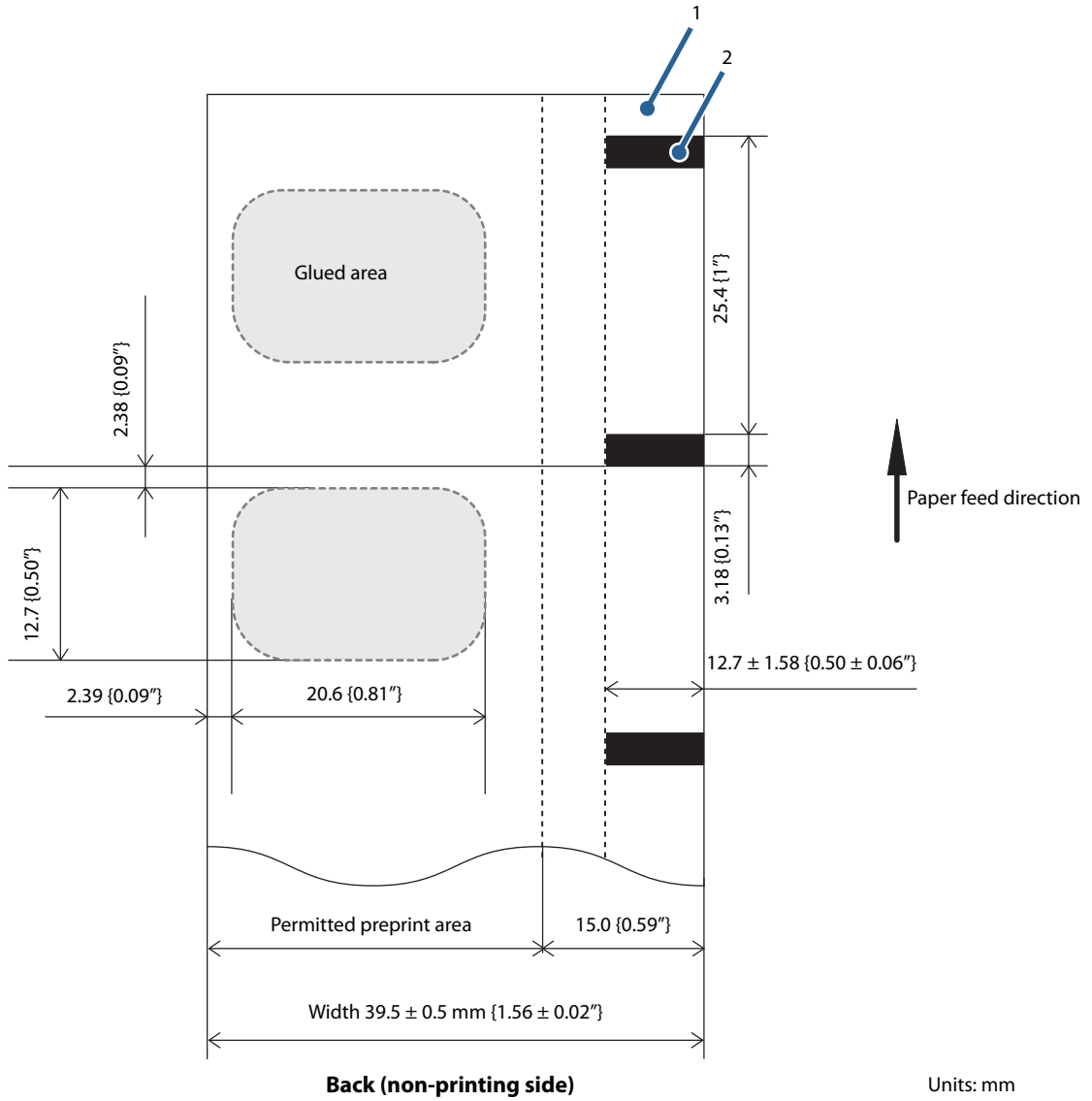

Thermal paper specifications

When using thermal paper, the paper must meet the following conditions:

Non-printing side

- Black marks or similar marks are NOT printed on the back (non-printing side)
 - The reflection rate of prohibited preprint area is 70% or more
- Note: Reflection rates are measured by the Macbeth PCM-II (Filter D). The back of the paper is measured.

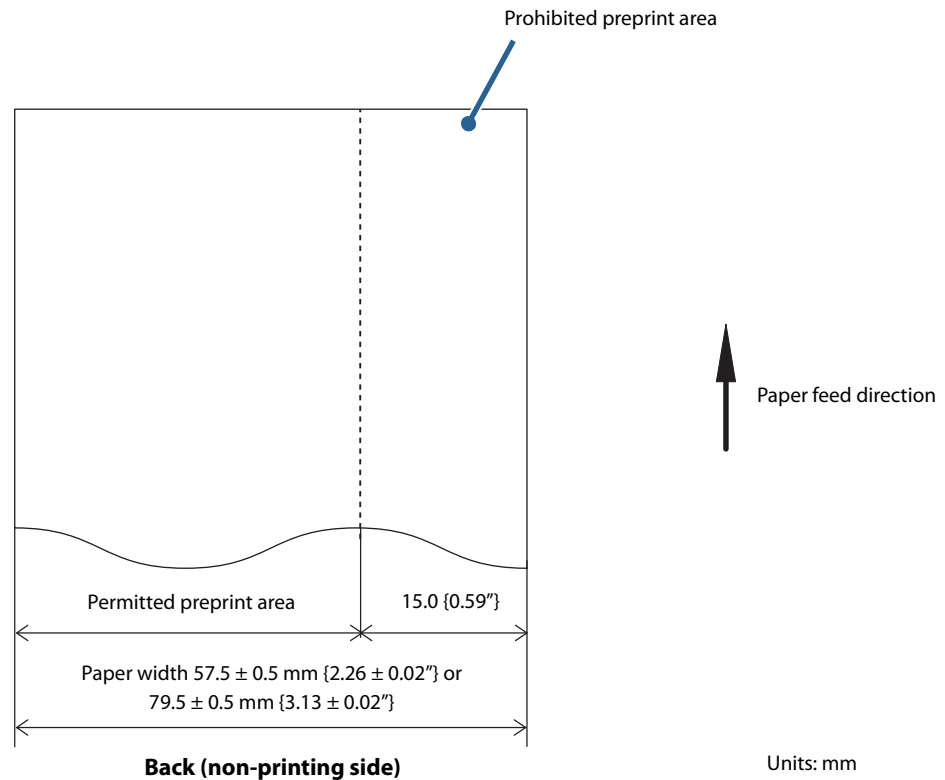

Printing side

- No preprint in the area shown below

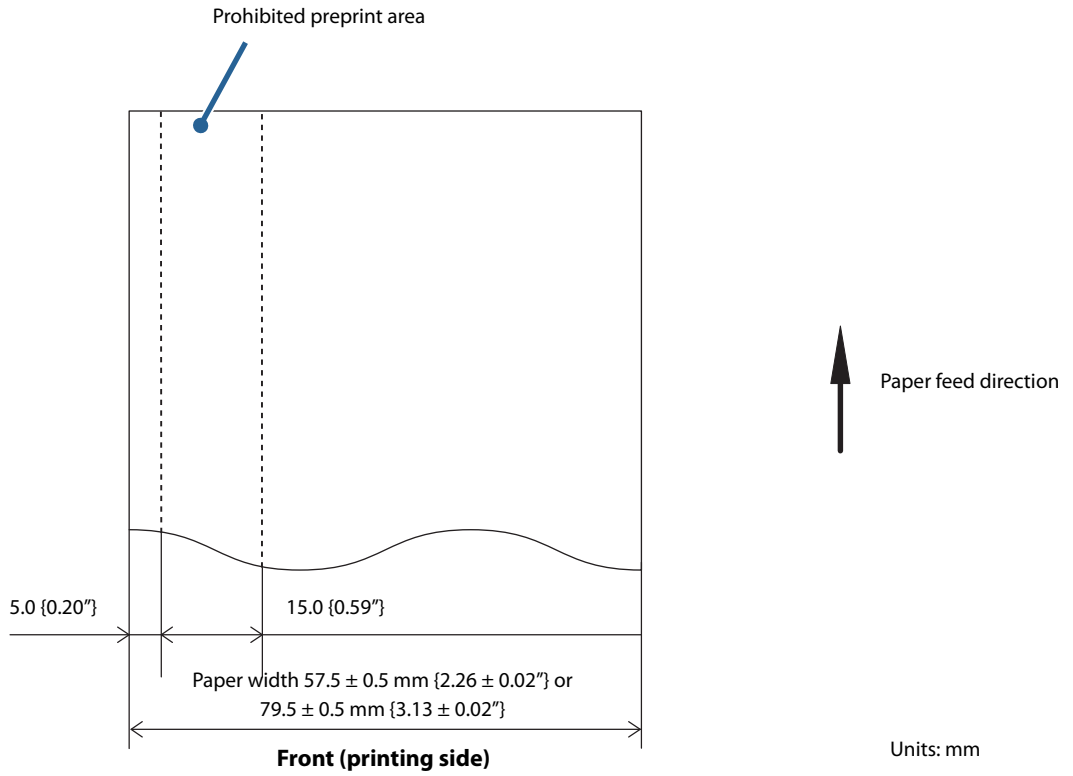

Printable Area

The print area may be out of alignment by 2 mm {0.08"} maximum to the left or right. When setting the print area, refer to the table and figure below to allow enough margins to the left and right.

Paper width (mm)	80	70	65	60	58	50	45	38
Printable area	72 {2.83"}	64 {2.52"}	59 {2.32"}	54 {2.13"}	52 {2.05"}	44 {1.73"}	39 {1.54"}	32 {1.26"}
Left margin	2.65 {0.10"}	2.65 {0.10"}	2.65 {0.10"}	2.65 {0.10"}	2.65 {0.10"}	2.65 {0.10"}	2.65 {0.10"}	2.65 {0.10"}
Right margin	4.85 {0.19"}	2.85 {0.11"}	2.85 {0.11"}	2.85 {0.11"}	2.85 {0.11"}	2.85 {0.11"}	2.85 {0.11"}	2.85 {0.11"}
Total number of dots	576	512	472	432	416	352	312	256

Units: mm

80 mm width paper

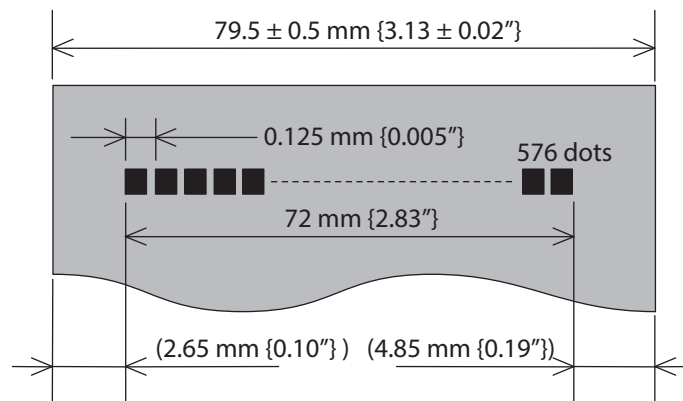

58 mm width paper

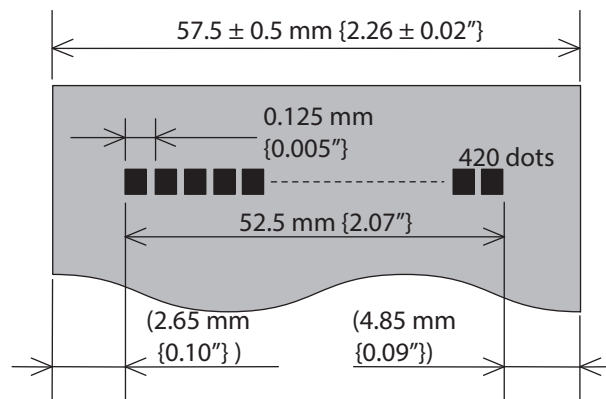

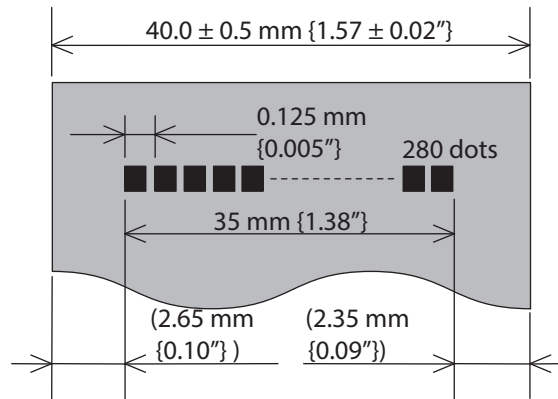
40 mm width paper

Printing and Cutting Positions

CAUTION

- The values above may vary slightly as a result of paper slack or variations in the paper. Take this into account when setting the cutting position of the autocutter.
- To prevent paper jams and for the best print quality, it is recommended to feed the paper by 1 mm {0.04"} or more after a paper cut.

NOTE

The printing and autocutting positions change depending on the paper type or the software setting. ("[Printing and Cutting Positions With Software Setting](#)" on page 94)

Non-68* models/68* models with paper removal standby disabled

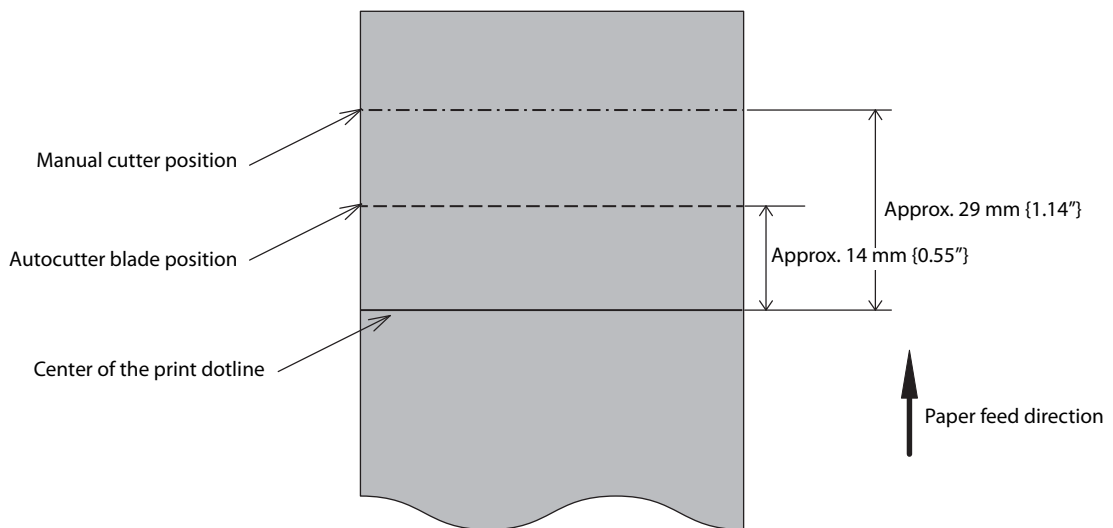

68* models with paper removal standby enabled

The print start position is adjustable with back feed.

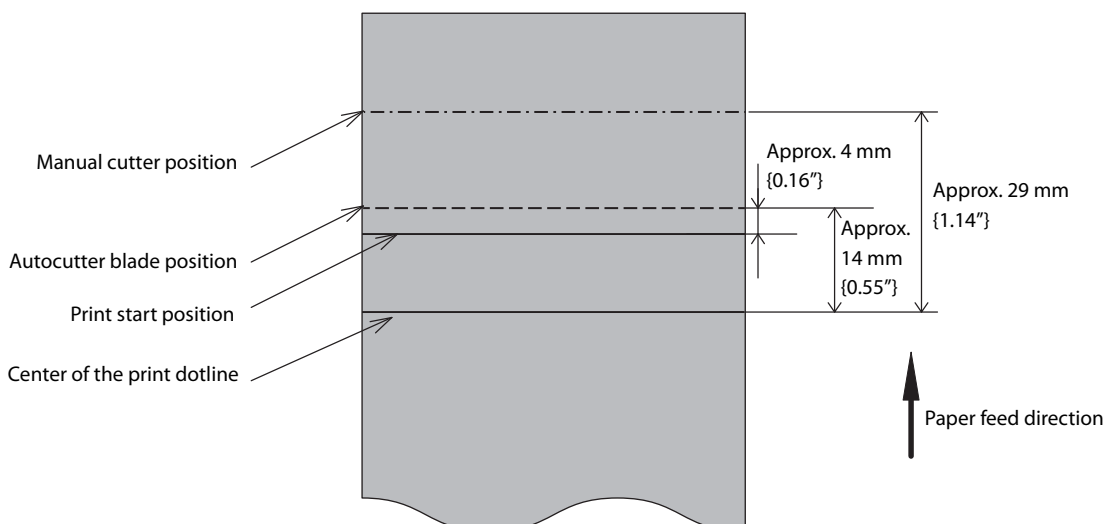

Electrical Characteristics

Supply voltage		DC 24 V \pm 7%
Current consumption (at 24 V, 25°C with standard print density)	Standby	Average: Approx. 0.1 A Maximum 1 A for drawer kick driving.
	Operating	Average: Approx. 1.8 A Note: According to the following operation conditions: <ul style="list-style-type: none"> • Font A • 44 digits • ASCII character continuous 50 lines + 5-line paper feeding + autocutting (Repetition from 20h to 7Fh)

Environmental Conditions

		Thermal paper	Liner-free label paper*
Temperature/Humidity	Operating	5°C to 45°C {41°F to 113°F}, 10% to 90% RH, non-condensing (See the operating environment range below.)	5°C to 35°C {41°F to 95°F}, 20% to 80% RH, non-condensing (See the operating environment range below.)
	Storage	-10°C to 50°C {14°F to 122°F}, 10% to 90%RH (paper excluded)	-10°C to 50°C {14°F to 122°F}, 10% to 90%RH (paper excluded)
Vibration resistance	When packed:	Frequency: 5 to 55 Hz Acceleration: Approximately 19.6 m/s ² {2G} Sweep: 10 minutes (half cycle) Duration: 1 hour Directions: XYZ There is no external or internal visible damage and the unit operates normally after being subjected to vibration.	
Impact resistance	When packed:	Package: EPSON standard package Height: 60 cm {23.62"} Directions: corner, 3 edges, and 6 surfaces There is no external or internal visible damage and the unit operates normally after being dropped.	
	When unpacked:	Height: 5 cm Directions: Lift one edge and release it There is no external or internal visible damage and the unit operates normally after being dropped while not operating.	
Acoustic noise	Operating	Approximately 52 dB (ANSI Bystander position) NOTE) The values above are measured in the Epson evaluation condition. Acoustic noise differs depending on the paper used, printing contents, and the setting values, such as print speed or print density.	

*: When the specified roll paper type is used ("[Paper Specifications](#)" on page 83)

External Dimensions and Mass

- Height: 148 mm {5.83"}
- Width: 140 mm {5.51"}
- Depth: 203 mm {7.99"}
- Mass: Approximately 1.9 kg {4.19 lb} (roll paper excluded)

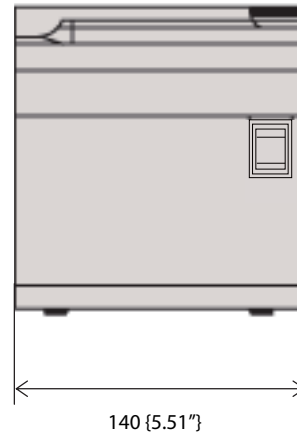
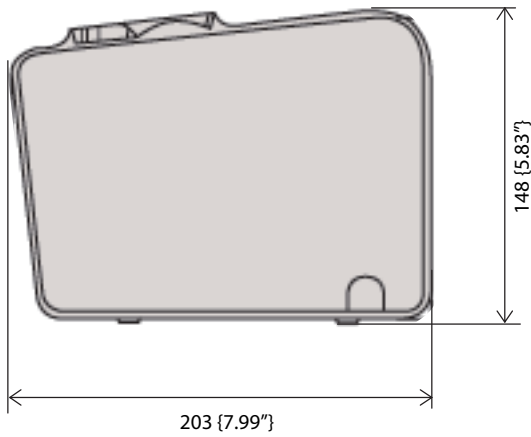

Units: mm

Printing and Cutting Positions With Software Setting

The printing and autocutting positions change depending on the paper type or the software setting.
 ("Software Settings" on page 37)

SW setting	Paper removal standby	Enabled	Disabled			
	Stop position for cutting	-	Arbitrary stop position		Specific stop position	
Paper	Auto top margin scaling	-	Disabled	Enabled	Disabled	Enabled
Liner-free label paper	MSW6-1 Cut at black mark position	Pattern A	Pattern A	Pattern D	Pattern A	Pattern D
	MSW6-1 Cut regardless of black mark position	Specified by command	Specified by command	Pattern C	Pattern B	Pattern C
Thermal paper	-	Specified by command	Specified by command	Pattern E	-	-

Pattern A

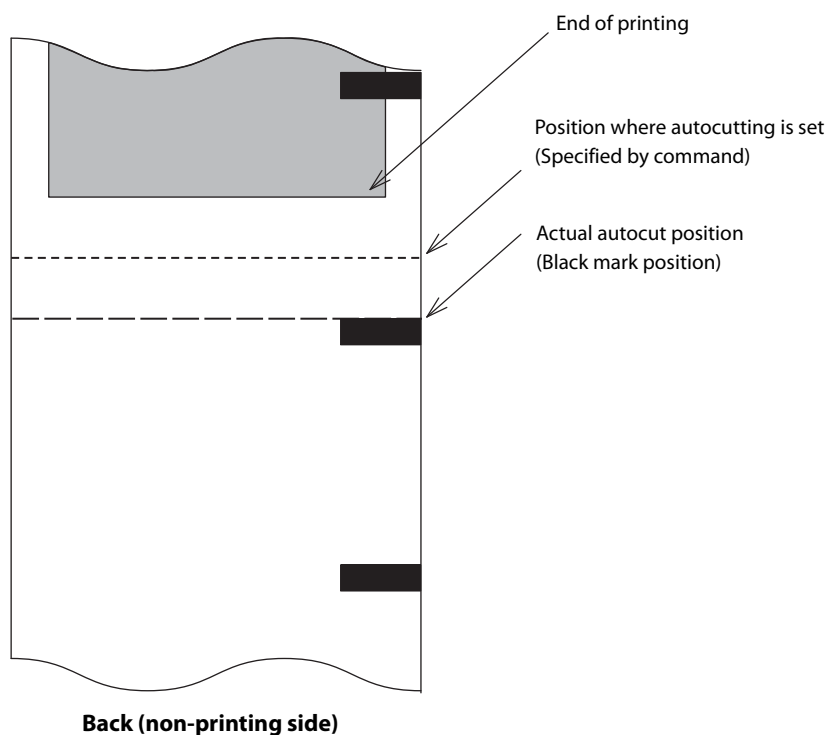

Top margin of next label

SW setting	Paper removal standby	Enabled	Disabled	
	Stop position for cutting	-	Arbitrary stop position	Specific stop position
Paper	Auto top margin scaling	-	Disabled	Disabled
Liner-free label paper	MSW6-1 Cut at black mark position	4 mm {0.16"}	Approx. 14 mm {0.55"}	Paper width 40 mm: approx. 24 mm {0.94"} Paper width 80 mm: approx. 26 mm {1.02"}

NOTE

- Autocutting is performed at the black mark position that is below the end-of-printing position. If the autocutting position is close to the black mark, the black mark may be skipped and autocutting may be performed at the next black mark position due to paper slack or variations in the paper, or differences in an individual printer.
- When autocutting is executed by an autocutting command along with paper feeding, autocutting is performed at the black mark position that is below the position where autocutting is set.
- For information on continuous multiple label printing, see ["Pattern D" on page 98](#).

Pattern B

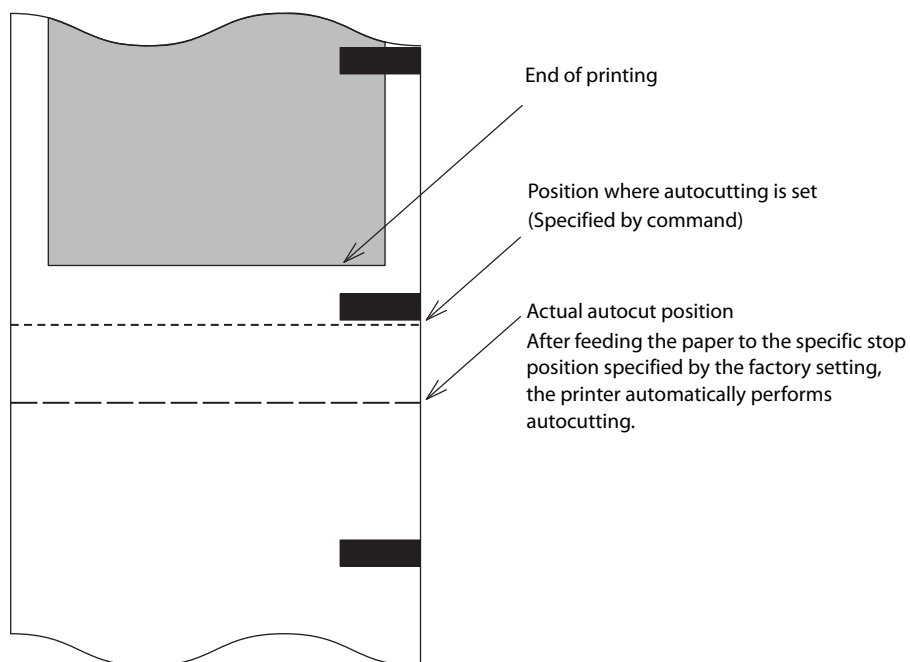

Top margin of next label

SW setting	Paper removal standby	Disabled	
	Stop position for cutting	Arbitrary stop position	Specific stop position
Paper	Auto top margin scaling	Disabled	Disabled
Liner-free label paper	MSW6-1 Cut at black mark position	4 to 14 mm {0.16 to 0.55"}	Paper width 40 mm: approx. 14 mm {0.55"} Paper width 80 mm: approx. 16 mm {0.63"}

NOTE

- If the printer has received print data for the next label at the time of autcutting, the printer performs autcutting at the position specified by command.
When the printer has not received print data for the next label, the printer automatically feeds the paper to the specific stop position (fixed at the factory before shipping) below the end-of-printing position, and performs autcutting. This may make the bottom margin larger than the one based on the position where autcutting is set.
- The specific stop position is determined by the position where a black mark is detected. Therefore, if the autcutting position is close to the specific stop position, the printer feeds the paper to the next specific stop position and performs autcutting, due to paper slack or variations in the paper, or differences in an individual printer.
- When autcutting is executed by an autcutting command along with paper feeding, autcutting is performed after paper is fed to the specific stop position that is below the paper feed position specified by command.
- For information on continuous multiple label printing, see ["Pattern C" on page 97](#).

Pattern C

Autocutting is performed at the specified paper cut position. However, when the label length is shorter than 35 mm {1.38"}, the printer feeds the paper to the point where the label length is 35 mm {1.38"}, and then performs autocutting.

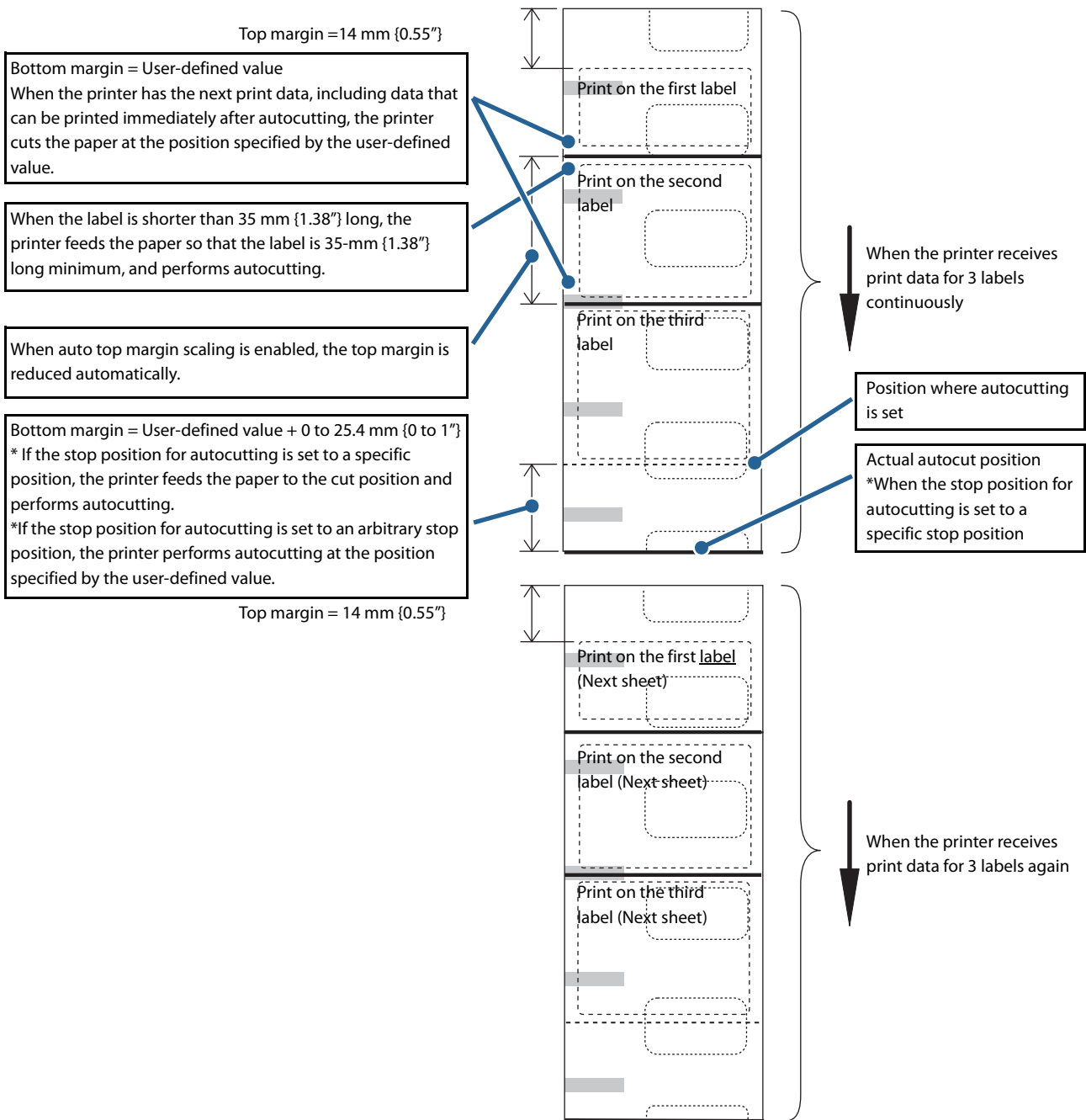

Pattern D

Autocutting is performed at the black mark position.

Top margin

When the stop position for autocutting is set to a specific stop position:

Approx. 24 mm {0.94"} when using 40 mm width liner-free label paper

Approx. 26 mm {1.02"} when using 80 mm width liner-free label paper

When the stop position for autocutting is set to an arbitrary stop position

14 mm {0.55"}

When auto top margin scaling is enabled, the top margin is reduced automatically.

Bottom margin = User-defined value + 0 to 25.4 mm {0 to 1"}
 * To ensure cutting at the top edge of the black mark, the printer automatically feeds the paper to the autocut position, and performs autocutting.

Top margin

When the stop position for autocutting is set to a specific stop position:

Approx. 24 mm {0.94"} when using 40 mm width liner-free label paper

Approx. 26 mm {1.02"} when using 80 mm width liner-free label paper

When the stop position for autocutting is set to an arbitrary stop position

14 mm {0.55"}

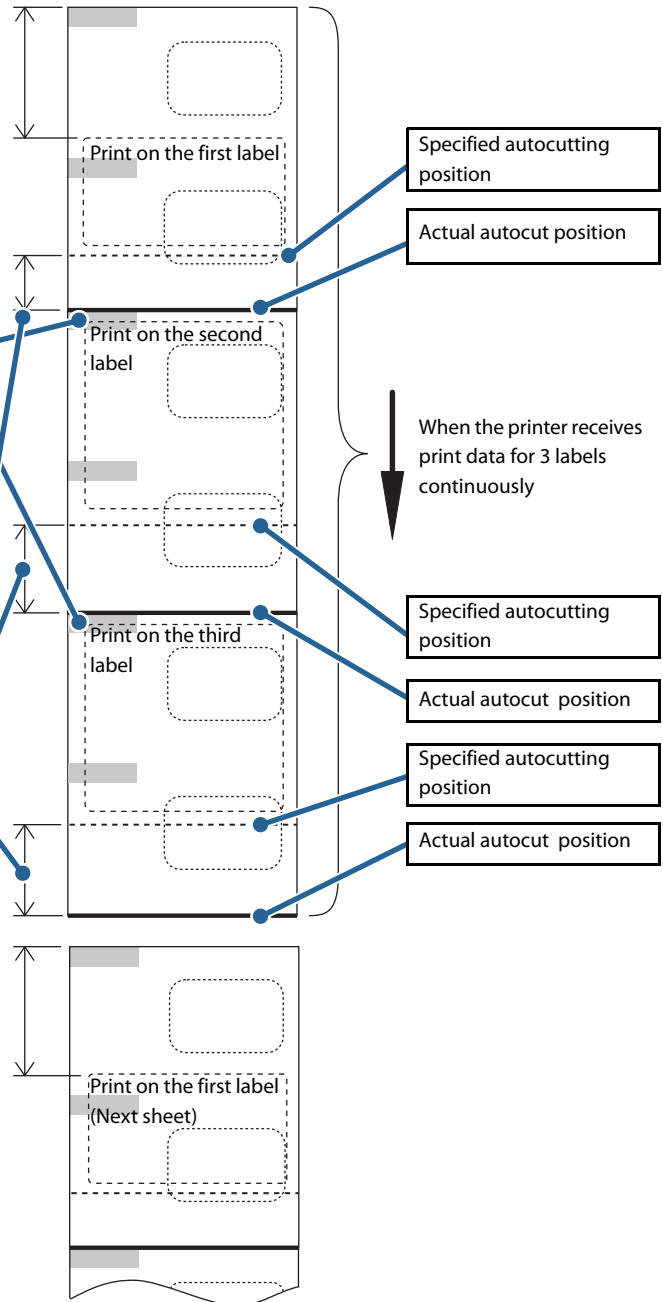

Pattern E

Thermal paper
Msw6-3 (Enabled)

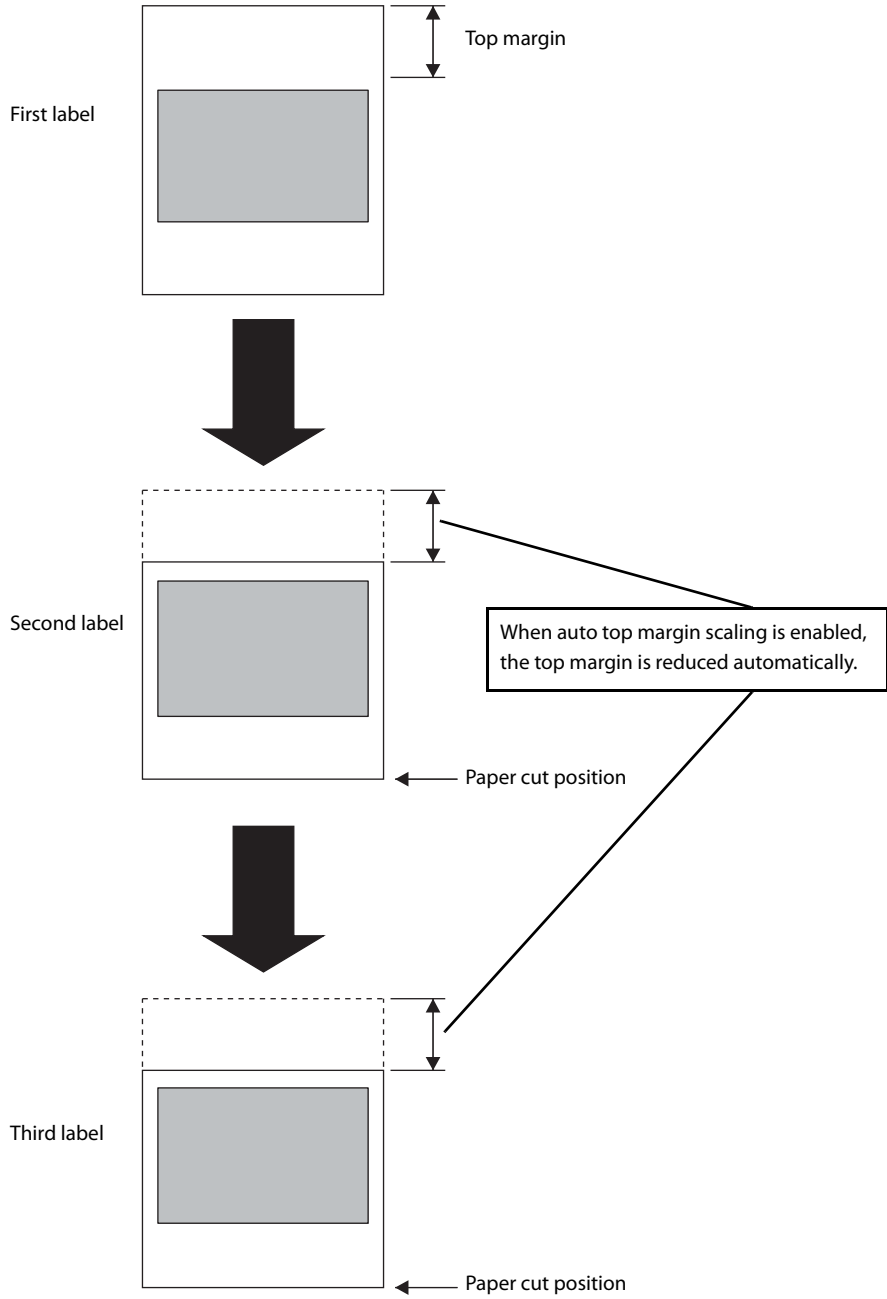

Specifications of Interfaces and Connectors

NOTE

For information about the Ethernet LAN interface model and wireless LAN interface model, see the technical reference guide for the applicable model.

RS-232 Serial Interface

Interface board specifications (RS-232-compliant)

Item		Specifications
Data transfer method		Serial
Synchronization		Asynchronous
Handshaking*		<ul style="list-style-type: none"> • DTR/DSR • XON/XOFF
Signal level	MARK	-3V to -15V logic "1"/OFF
	SPACE	+3V to +15V logic "0"/ON
Bit length*		<ul style="list-style-type: none"> • 7 bits • 8 bits
Transmission speed*		2400 bps, 4800 bps, 9600 bps, 19200 bps, 38400 bps, 57600 bps, 115200 bps [bps: bits per second]
Parity check*		<ul style="list-style-type: none"> • Yes • No
Parity selection*		<ul style="list-style-type: none"> • Even • Odd
Stop bit		1 or more bits However, the stop bit for data transfer from the printer is fixed to 1 bit.
Connector	Printer side	DSUB 25-pin (female) connector

* : Selectable using the memory switches ("[Communication condition of serial interface](#)" on page 47)

Functions of interface connector pins

Pin no.	Signal name	Signal direction	Function
1	FG	-	Frame ground
2	TXD	Output	Transmission data
3	RXD	Input	Reception data
4	RTS	Output	Equivalent to DTR signal (pin 20)
6	DSR	Input	<p>This signal indicates whether the host computer can receive data. SPACE indicates that the host computer can receive data. MARK indicates that the host computer cannot receive data.</p> <p>When DTR/DSR control is selected, the printer transmits data after confirming this signal. (except if transmitted using some ESC/POS commands).</p> <p>When XON/XOFF control is selected, the printer does not check this signal.</p>
7	SG	-	Signal ground
20	DTR	Output	<p>1) When DTR/DSR control is selected, this signal indicates whether the printer is BUSY.</p> <ul style="list-style-type: none"> • SPACE status <p>Indicates that the printer is ready to receive data.</p> <ul style="list-style-type: none"> • MARK status <p>Indicates that the printer is BUSY. The BUSY condition can be specified using memory switch 1-3.</p> <p>2) When XON/XOFF control is selected, this signal indicates whether the printer is properly connected and ready to receive data from the host.</p> <ul style="list-style-type: none"> • SPACE status <p>The signal indicates that the printer is properly connected and ready to receive data from the host.</p> <p>The signal is always SPACE, except in the following cases.</p> <p>During the period from when power is turned on to when the printer is ready to receive data.</p> <p>While the self-test is in progress.</p>
25	INIT	Input	<p>The printer can use this signal as a reset signal.</p> <p>The printer is reset if the signal remains at SPACE for a pulse width of 1 ms or more.</p>

XON/XOFF

When XON/XOFF control is selected, the printer transmits the XON or XOFF signals as follows. XON/XOFF transmission timing differs depending on the memory switch 1-3 setting.

Signal	Printer status	Memory switch 1-3	
		ON	OFF
XON	1) When the printer goes online after turning on the power (or after reset using the interface)	Transmit	Transmit
	2) When the receive buffer is released from the buffer full state	Transmit	Transmit
	3) When the printer switches from offline to online	-	Transmit
	4) When the printer recovers from an error using some ESC/POS commands	-	Transmit
XOFF	5) When the receive buffer becomes full	Transmit	Transmit
	6) When the printer switches from online to offline	-	Transmit

Code

The hexadecimal numbers corresponding to the XON/XOFF codes are shown below.

- XON code: 11H
- XOFF code: 13H

CAUTION

- When the printer goes from offline to online and the receive buffer is full, XON is not transmitted.
- When the printer goes from online to offline and the receive buffer is full, XOFF is not transmitted.
- When memory switch 1-3 is set to OFF, XON is not transmitted as long as the printer is offline, even if a receive buffer full state has been cleared.

USB (Universal Serial Bus) Interface

Description

- Full-speed transmission at 12 Mbps [bps: bits per second]
- Plug & Play, Hot Insertion & Removable

USB transmission specifications

USB function

Overall specifications	Compliant to USB 2.0 specifications	
Transmission speed	USB Full-Speed (12 Mbps)	
Transmission method	USB bulk transmission method	
Power supply specifications	USB self power supply function	
Current consumed by USB bus	2 mA	
USB packet size (full-speed connection)	USB bulk OUT (TM)	64 bytes
	USB bulk IN (TM)	64 bytes
USB device class	Vendor-defined class	

USB descriptor

		USB vendor-defined class
Vendor ID		04B8h
Product ID		0202h
String Descriptor	Manufacturer	EPSON
	Product	TM-L90
	Serial number	Character string based on the product serial number

Status transmission from printer with USB interface

In order to avoid lack of status data, it is necessary to periodically retrieve status data at the host PC. Unlike RS-232, the USB bulk transmission method cannot interrupt data transmission to the host. The printer has a 128-byte status buffer. Statuses that exceed the buffer capacity are canceled.

Character Code Tables

Refer to the following URL regarding the character code table.
www.epson-biz.com/pos/reference/charcode/