

Industrial Panel PC SLT-15

15" All in One Panel PC with Intel® Core i3, i5 CPU

Product Features:

- Intel® Core i3/i5 CPU
- Supports Multi-Touch
- Flat Front Panel with IP66 Design
- Resistive Touch or Projected Capacitive Touch
- High Brightness 1000nits (optional)



Product Specifications:

Mechanical	Model Name	SLT-15
	Display Type	15" TFT-LCD
	Max Resolution	1024 x 768
System	Processor	Intel® Core i3/i5 CPU (optional)
	Chipset	Intel®
	Memory	4GB Max. 16GB (optional)
	IDE/SATA	Msata SSD
	Luminance/Color	400cd/m ² , 16.7m 1000nits optional
	Input / Output	USB Port
Input / Output	Ethernet	2 x GbE LAN RJ-45
	HDMI	1 x HDMI
	VGA	1 x VGA
	COM	2 x RS-232
	Audio	1 x Line out, 1 x Lin In.
	View Angle	H: 160° / V:160°
Power	Power Input	DC 12~30V
Environment	Operating Temperature	-10° to 60°C
	Storage Temperature	-20° to 60°C
	Wi-Fi / Bluetooth	(Options)
OS Support	Windows 10 Pro, Linux	
	Standard Color	Black
	Construction	Aluminum alloy bezel and chassis
	Mounting	Panel, VESA 75x75mm / 100x100mm
	IP Rating	IP66 compliant front panel
	Dimensions	378mm(W) x 56mm(D) x 297mm(H)
	Weight	12 lbs.
	Certification	CE/FCC Class A

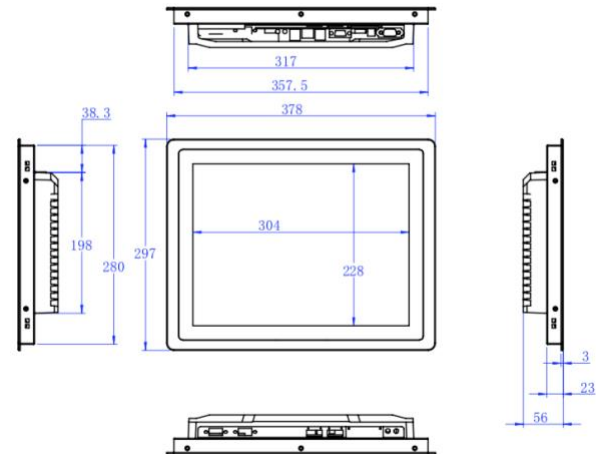

Note: All Specifications are subject to change without prior notice.