

NOTES: UNLESS OTHERWISE SPECIFIED

1. MATERIAL: 20 GAUGE (.0359" THK) CRS
2. PRIME AND PAINT PER PURCHASE ORDER
3. BREAK SHARP EDGES .015R MAX

16X LASER CUT  
TO ALLOW BREAK OFF  
OF TABS AS NEEDED

(.06)      (.06)

DETAIL A  
SCALE 4.000

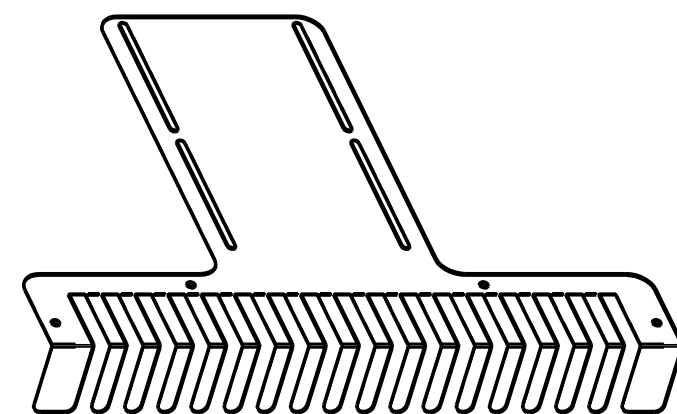

SCALE 0.250

REVISIONS				
REV.	DESCRIPTION	CHK	APPD	DATE
A	RELEASE			2/19/11
B	18X WAS 16X; ADD-SCORE ALL FINGERS AND END TABS TO ALLOW TO BE BENT AND BROKEN OFF AS NEEDED			5/7/14
C	DEL SCORE ALL FINGERS NOTE; ADD 16X LASER CUTS AND DETAIL A			8/3/14
D	4X 2.25 X .187 SLOTS WAS 4X Ø.187, 11.00 INSIDE WAS 9.00 INSIDE, 4X .187 WAS 8X .187			11/30/15
E	3.73 WAS 2.53, 1.30 WAS 2.5, 4X 3.45 WAS 4X 2.25, 1.75 WAS 2.00			2/23/16

THIRD ANGLE PROJECTION TOLERANCES: 2 DEC PLCS: ±.015 3 DEC PLCS: ±.005 ANGLES: ±1° DEBURR ALL EDGES	PRODUCT LINE:		TITLE:  GUARD, CONNECTOR	
	DRAWN: S.K.	2/19/11		
FINISH: SEE NOTE 2	CHECKED:	APPROVED:	REV: E	<b>41001076</b>
MATL: SEE NOTE 1	ISSUED:		<b>C</b>	SCALE: 1/2 SHEET 1 OF 1